

EXPLODED VIEW

CODE: E 10155 Rev.:01

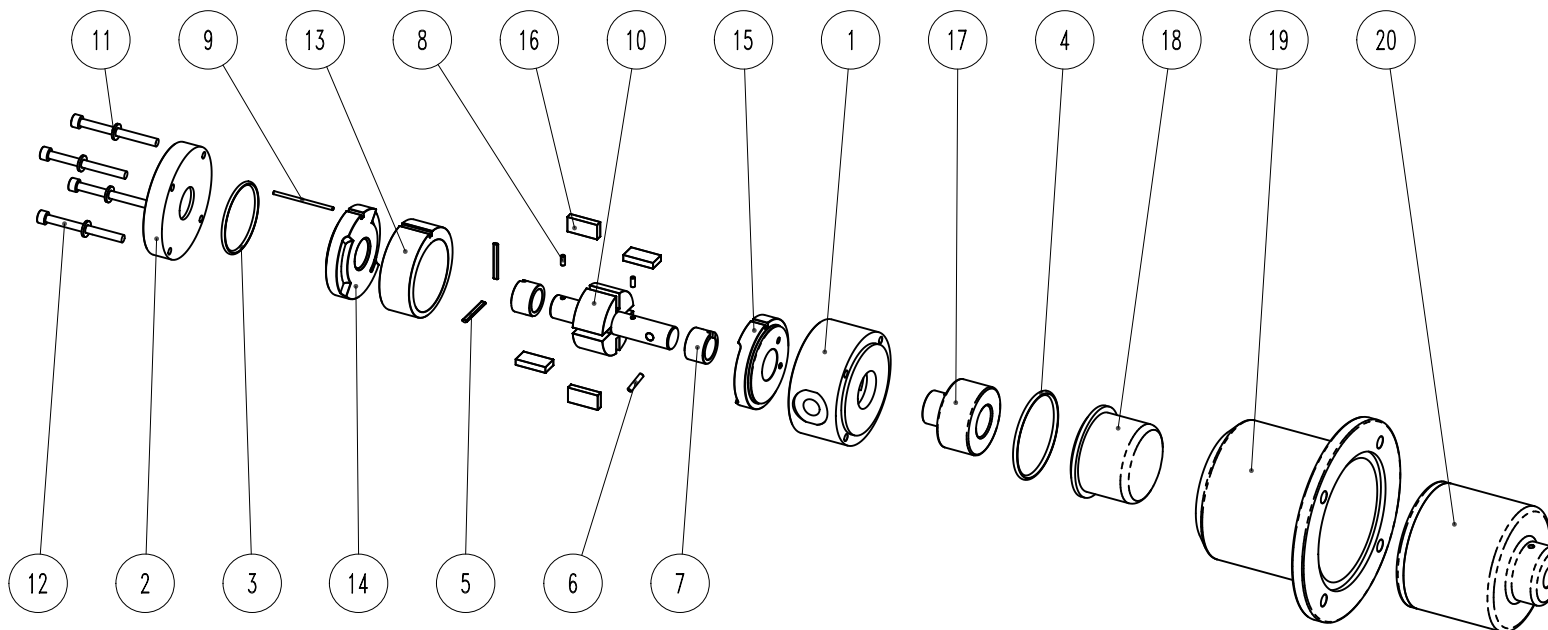

ITEM: Pump model: VPA PP

PART LIST

ITEM N°	META CODE	Description	Material	Q.ty	ITEM N°	META CODE	Description	Material	Q.ty
1	56220VPAPG	Pump Casing BSP	PP	1	12	91610TCEI570A2	Screw UNI5931 M5x70	A2-70	4
	56220VPAPN	Pump Casing NPT				92410FVA01	Stator VA 100 L/h	Graphite	1
2	55520VPAP	Pump casing cover	PP	1	13	92410FVA02	Stator VA 200 L/h		
3	92910E3769	O-Ring 4150/BS222	EPDM	1		92410FVA03	Stator VA 300 L/h		
4	92910E6309	O-Ring 4250/BS230	EPDM	1	92410FVA04	Stator VA 400 L/h			
5	91650V0100	Pins L100	PVDF	2	14	91110FVAAS	Front Disc	Graphite	1
	91650V0200	Pins L200			15	91110FVAPS	Rear Disc	Graphite	1
	91650V0300	Pins L300/400			16	92010FVA	Vane	Graphite	4
6	96610D050025V	Lock pins	PVDF	1	17	55820VPNP	Internal magnet	PP/NdFeB	1
7	90230S0016095	Sleeve rotor	SiC	2	18	55610VPAP	Rear casing	PP	1
8	56610D030010V	Lock pins sleeve rotor	PVDF	2	19	56110VPA06L	Bracket	Aluminium	1
9	91650VPV	Guide pins	PVDF	1	20	55810VP06N	External magnet	A105/NdFeB	1
10	50160VPAVF	Rotor	PVDF 10%FC	1					
11	91630N0510A2	Washer UNI6592 D.5x10	A2-70	4					

Motor: IEC 71 B3/B5
 Port connection: Threaded
 BSP-F UNI ISO 228/1 | NPT-F USAS B2-1/1968

- This drawing is for reference only

EXPLODED VIEW

CODE: E 10156 Rev.:01

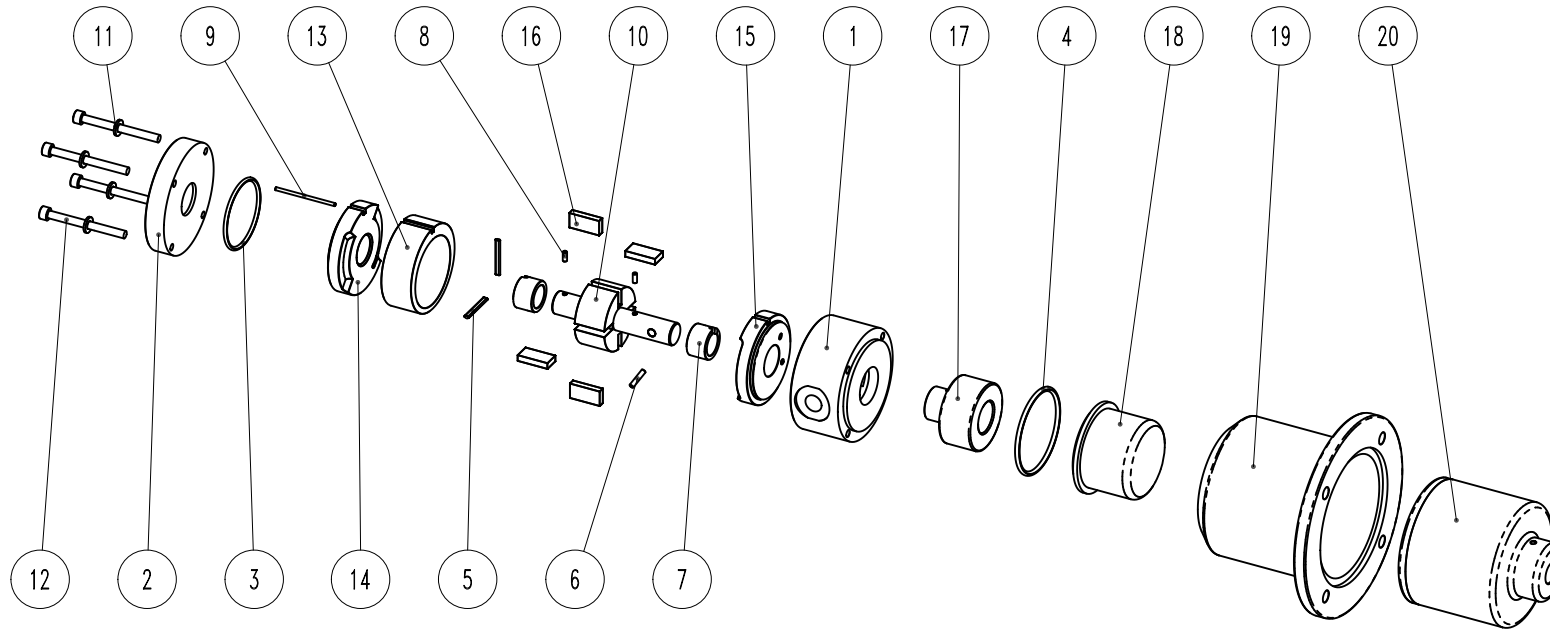

ITEM: Pump model: VPA PVDF

PART LIST

ITEM N°	META CODE	Description	Material	Q.ty	ITEM N°	META CODE	Description	Material	Q.ty
1	56220VPAVG	Pump Casing BSP	PVDF	1	12	91610TCEI570A2	Screw UNI5931 M5x70	A2-70	4
	56220VPAVN	Pump Casing NPT							
2	55520VPAV	Pump casing cover	PVDF	1	13	92410FVA01	Stator VA 100 L/h	Graphite	1
3	92910V3769	O-Ring 4150/BS222	Viton	1		92410FVA02	Stator VA 200 L/h		
4	92910V6309	O-Ring 4250/BS230	Viton	1		92410FVA03	Stator VA 300 L/h		
						92410FVA04	Stator VA 400 L/h		
5	91650V0100	Pins L100	PVDF	2	14	91110FVAAS	Front Disc	Graphite	1
	91650V0200	Pins L200			15	91110FVAPS	Rear Disc	Graphite	1
	91650V0300	Pins L300/400			16	92010FVA	Vane	Graphite	4
6	96610D050025V	Lock pins	PVDF	1	17	55820VPNV	Internal magnet	PVDF/NdFeB	1
7	90230S0016095	Sleeve rotor	SiC	2	18	55610VPAV	Rear casing	PVDF	1
8	56610D030010V	Lock pins sleeve rotor	PVDF	2	19	56110VPA06L	Bracket	Aluminium	1
9	91650VPV	Guide pins	PVDF	1	20	55810VP06N	External magnet	A105/NdFeB	1
10	50160VPAVF	Rotor	PVDF 10%FC	1					
11	91630N0510A2	Washer UNI6592 D.5x10	A2-70	4					

ITEM: Motor: IEC 71 B3/B5
 Port connection: Threaded
 BSP-F UNI ISO 228/1 | NPT-F USAS B2-1/1968

- This drawing is for reference only