

# EXPLODED VIEW

CODE: E 10395 Rev.:01

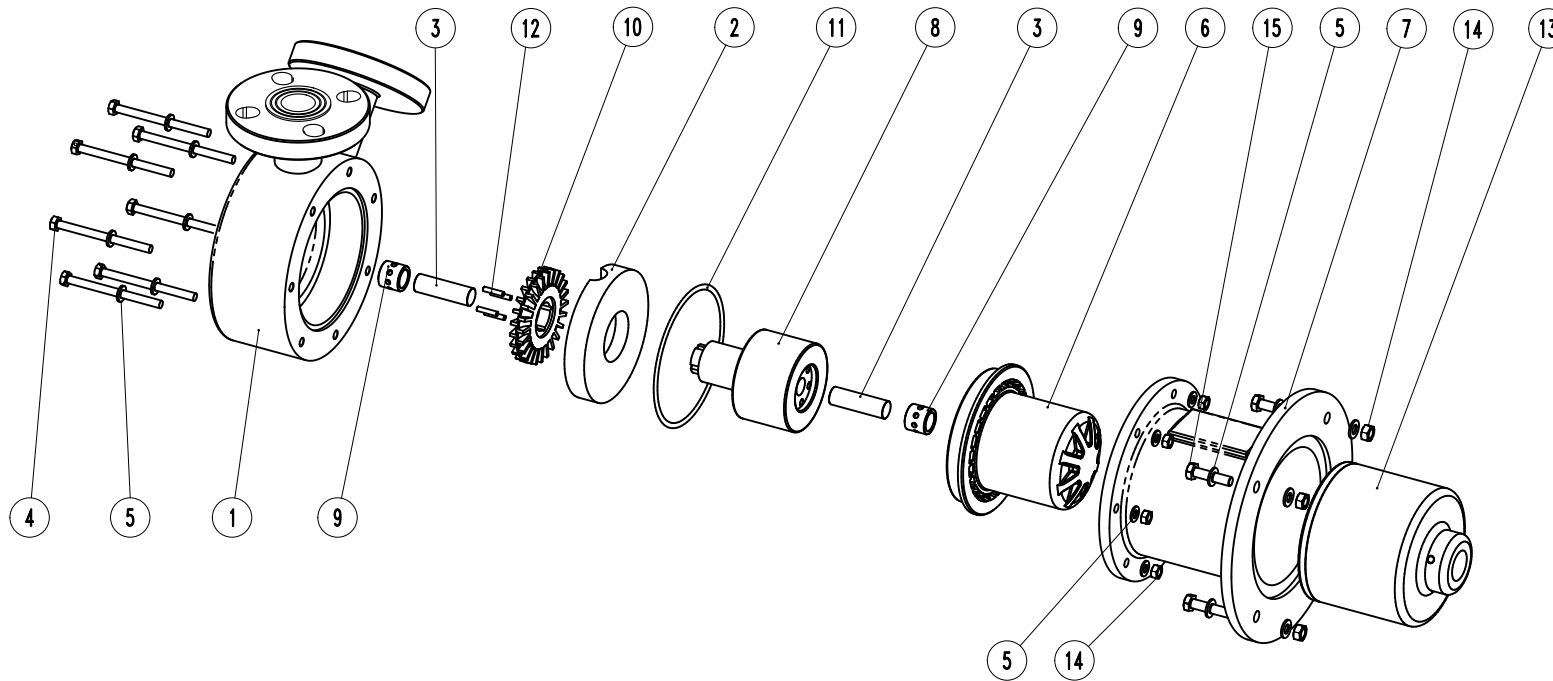

ITEM: Pump model: T MAG-P32 PP

# PART LIST

ITEM N°	CODE META	Description	Material	Q.ty	ITEM N°	CODE META	Description	Material	Q.ty
1	56220T1032PU	Pump Casing	PP	1	14	91620N06A2	Nut UNI5588 M6	A2-70	11
2	55120T1032P	Volute Ring	PP	1	15	91610TE630A2	Screw UNI24017 M6x30	A2-70	4
3	90010A01001	Front / Rear shaft	Al2o3	2					
4	91610TE670A2	Screw UNI24017 M6x70	A2-70	7					
5	91630N0612A2	Washer UNI6592 D.6x12	A2-70	22					
6	55610T1032P	Rear Casing	PP FV10%	1					
7	56120T102304D	Bracket	PP	1					
8	55820T1032AP	Internal Magnet	PP/NdFeB	1					
9	90310C201517	Bushing	PTFEC	2					
10	55710T1032P	Impeller	PP	1					
11	92910E9167	O-Ring 4362/BS239	EPDM	1					
12	56610D030015V	Impeller Pins	PVDF	2					
13	55810T103204N	External magnet	A105/NdFeB	1					

Motor: IEC Gr63 B5  
 Port connection: Flanged  
 UNI EN1092-1 PN.10 / ANSI (ASA) B16.5 150#

- This drawing is for reference only

# EXPLODED VIEW

CODE: E 10396 Rev.:01

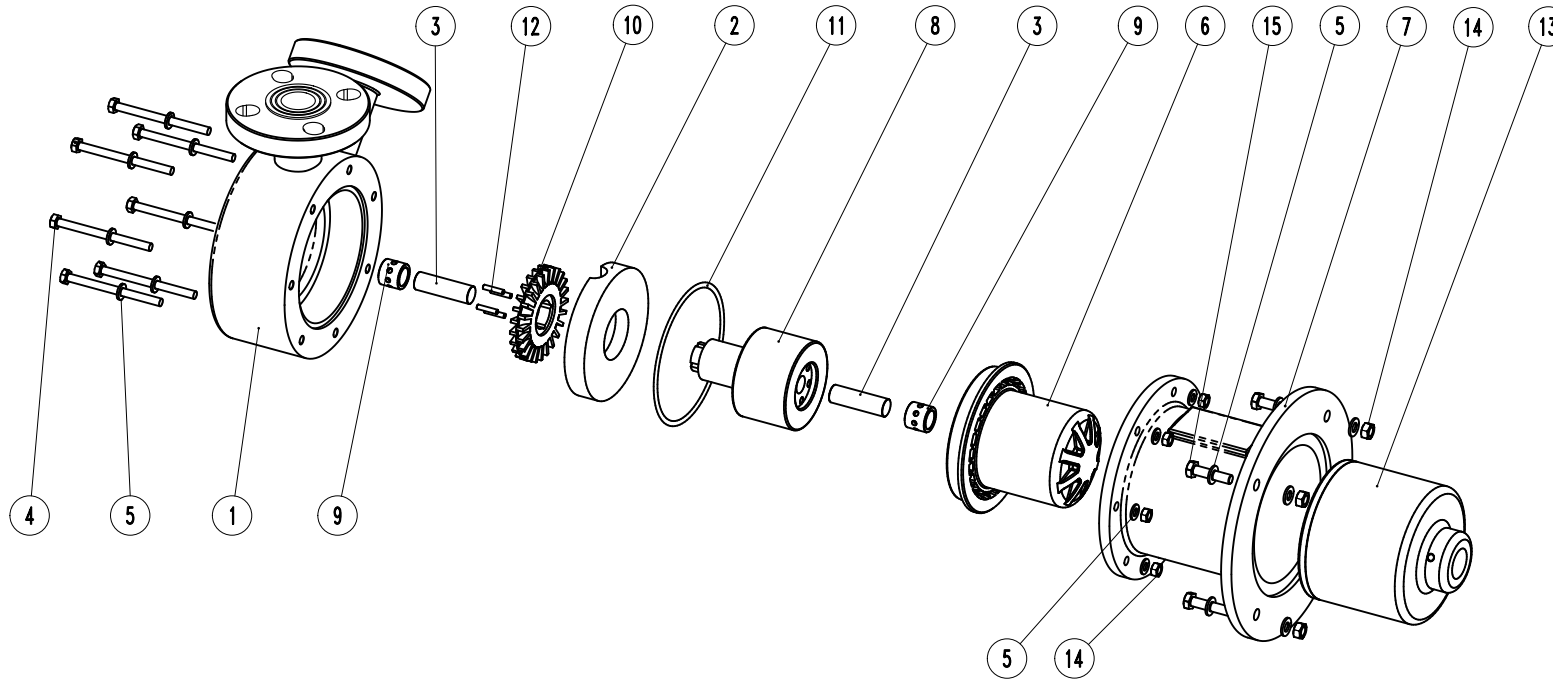

ITEM: Pump model: T MAG-P32 PVDF

# PART LIST

ITEM N°	CODE META	Description	Material	Q.ty	ITEM N°	CODE META	Description	Material	Q.ty
1	56220T1032VU	Pump Casing	PVDF	1	14	91620N06A2	Nut UNI5588 M6	A2-70	11
2	55120T1032V	Volute Ring	PVDF	1	15	91610TE630A2	Screw UNI24017 M6x30	A2-70	4
3	90010A01001	Front / Rear shaft	Al2o3	2					
4	91610TE670A2	Screw UNI24017 M6x70	A2-70	7					
5	91630N0612A2	Washer UNI6592 D.6x12	A2-70	22					
6	55610T1032V	Rear Casing	PVDF	1					
7	56120T102304D	Bracket	PP	1					
8	55820T1032AV	Internal Magnet	PVDF/NdFeB	1					
9	90310C201517	Bushing	PTFEC	2					
10	55710T1032V	Impeller	PVDF	1					
11	92910V9167	O-Ring 4362/BS239	VITON	1					
12	56610D030015V	Impeller Pins	PVDF	2					
13	55810T103204N	External magnet	A105/NdFeB	1					

Motor: IEC Gr63 B5  
 Port connection: Flanged  
 UNI EN1092-1 PN.10 / ANSI (ASA) B16.5 150#

- This drawing is for reference only

# EXPLODED VIEW

CODE: E 10397 Rev.:01

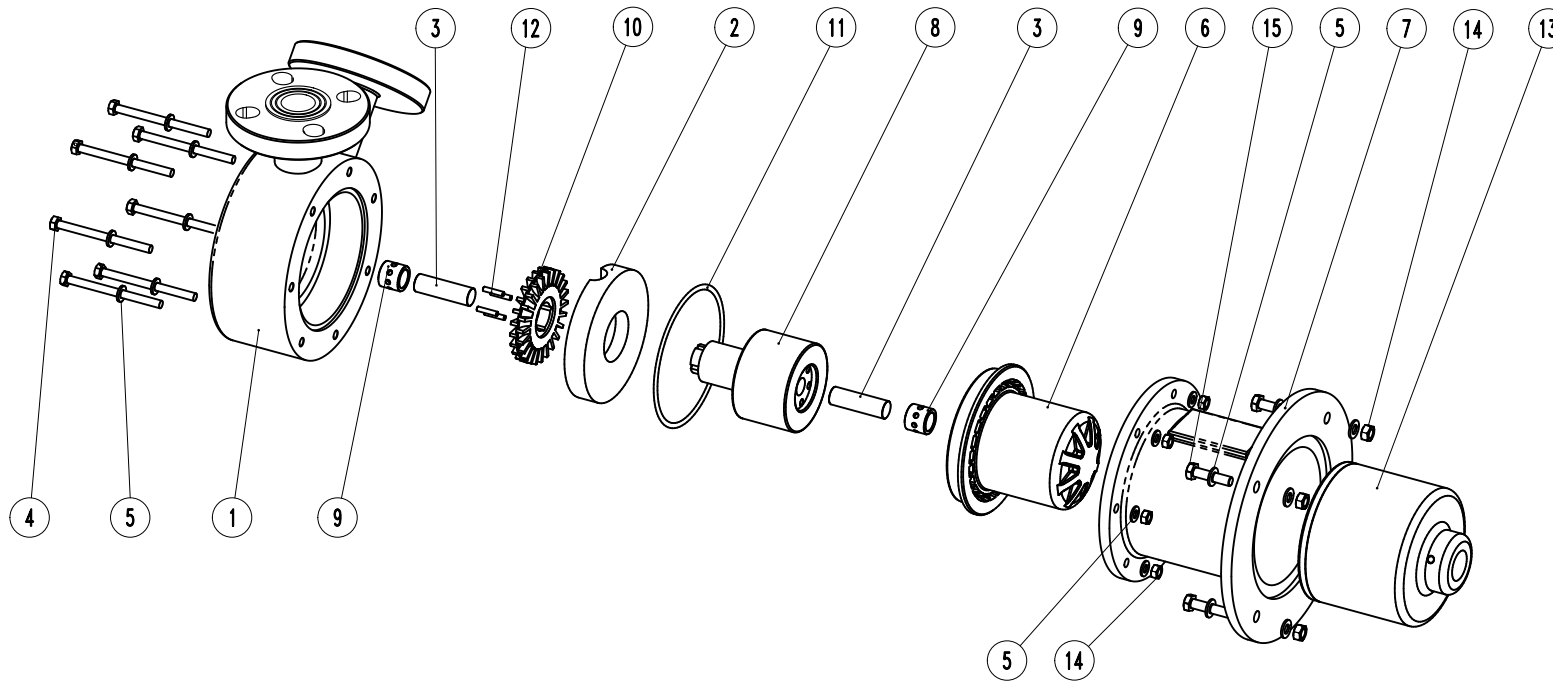

ITEM: Pump model: T MAG-P33 PP

# PART LIST

Motor: IEC Gr71 B5  
Port connection: Flanged

UNI EN1092-1 PN.10 / ANSI (ASA) B16.5 150#

ITEM N°	CODE META	Description	Material	Q.ty	ITEM N°	CODE META	Description	Material	Q.ty
1	56220T1032PU	Pump Casing	PP	1	14	91620N06A2	Nut UNI5588 M6	A2-70	11
2	55120T1032P	Volute Ring	PP	1	15	91610TE630A2	Screw UNI24017 M6x30	A2-70	4
3	90010A01001	Front / Rear shaft	Al2o3	2					
4	91610TE670A2	Screw UNI24017 M6x70	A2-70	7					
5	91630N0612A2	Washer UNI6592 D.6x12	A2-70	22					
6	55610T1052P	Rear Casing	PP FV10%	1					
7	56120T105206D	Bracket	PP	1					
8	55820T1033AP	Internal Magnet	PP/NdFeB	1					
9	90310C201517	Bushing	PTFEC	2					
10	55710T1032P	Impeller	PP	1					
11	92910E9167	O-Ring 4362/BS239	EPDM	1					
12	56610D030015V	Impeller Pins	PVDF	2					
13	55810T105206N	External magnet	A105/NdFeB	1					

- This drawing is for reference only

# EXPLODED VIEW

CODE: E 10398 Rev.:01

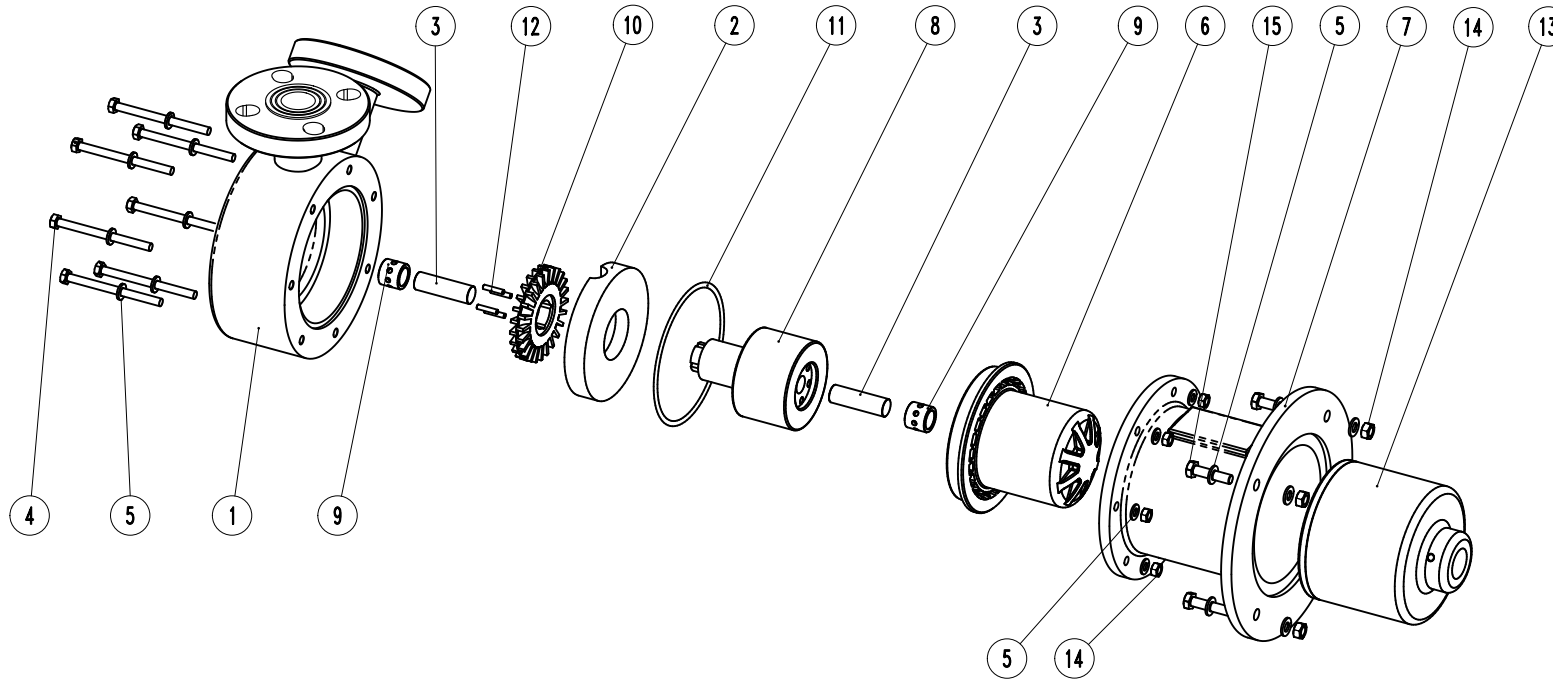

ITEM: Pump model: T MAG-P33 PVDF

# PART LIST

ITEM N°	CODE META	Description	Material	Q.ty	ITEM N°	CODE META	Description	Material	Q.ty
1	56220T1032VU	Pump Casing	PVDF	1	14	91620N06A2	Nut UNI5588 M6	A2-70	11
2	55120T1032V	Volute Ring	PVDF	1	15	91610TE630A2	Screw UNI24017 M6x30	A2-70	4
3	90010A01001	Front / Rear shaft	Al2o3	2					
4	91610TE670A2	Screw UNI24017 M6x70	A2-70	7					
5	91630N0612A2	Washer UNI6592 D.6x12	A2-70	22					
6	55610T1052V	Rear Casing	PVDF	1					
7	56120T105206D	Bracket	PP	1					
8	55820T1033AV	Internal Magnet	PVDF/NdFeB	1					
9	90310C201517	Bushing	PTFEC	2					
10	55710T1032V	Impeller	PVDF	1					
11	92910V9167	O-Ring 4362/BS239	VITON	1					
12	56610D030015V	Impeller Pins	PVDF	2					
13	55810T105206N	External magnet	A105/NdFeB	1					

Motor: IEC Gr71 B5  
 Port connection: Flanged  
 UNI EN1092-1 PN.10 / ANSI (ASA) B16.5 150#

- This drawing is for reference only

# EXPLODED VIEW

CODE: E 10399 Rev.:01

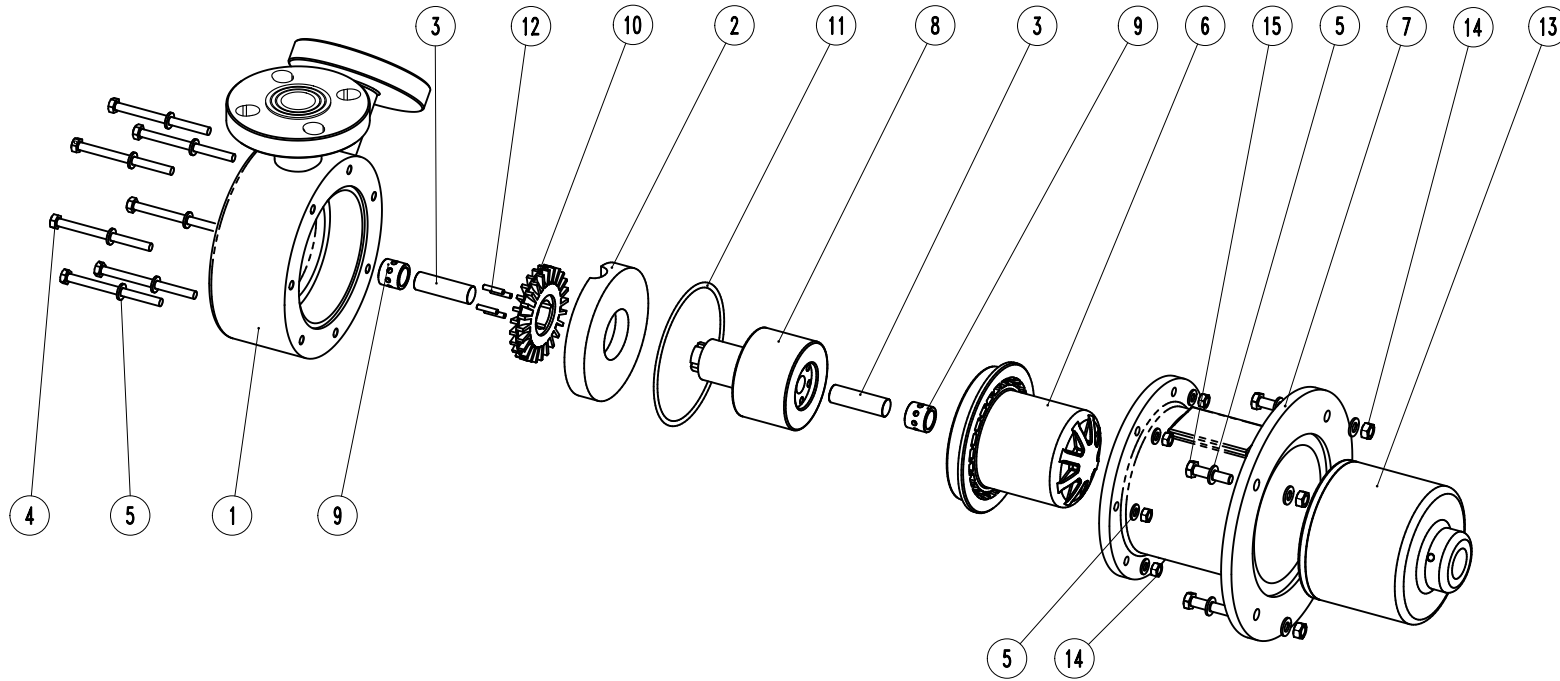

ITEM: Pump model: T MAG-P52 PP

# PART LIST

Motor: IEC Gr71 B5  
Port connection: Flanged

UNI EN1092-1 PN.10 / ANSI (ASA) B16.5 150#

ITEM N°	CODE META	Description	Material	Q.ty	ITEM N°	CODE META	Description	Material	Q.ty
1	56220T1052PU	Pump Casing	PP	1	14	91620N06A2	Nut UNI5588 M6	A2-70	11
2	55120T1052P	Volute Ring	PP	1	15	91610TE630A2	Screw UNI24017 M6x30	A2-70	4
3	90010A01001	Front / Rear shaft	Al2o3	2					
4	91610TE670A2	Screw UNI24017 M6x70	A2-70	7					
5	91630N0612A2	Washer UNI6592 D.6x12	A2-70	22					
6	55610T1052P	Rear Casing	PP FV10%	1					
7	56120T105206D	Bracket	PP	1					
8	55820T1052AP	Internal Magnet	PP/NdFeB	1					
9	90310C201517	Bushing	PTFEC	2					
10	55710T1052P	Impeller	PP	1					
11	92910E9167	O-Ring 4362/BS239	EPDM	1					
12	56610D030015V	Impeller Pins	PVDF	2					
13	55810T105206N	External magnet	A105/NdFeB	1					

- This drawing is for reference only

# EXPLODED VIEW

CODE: E 10400 Rev.:01

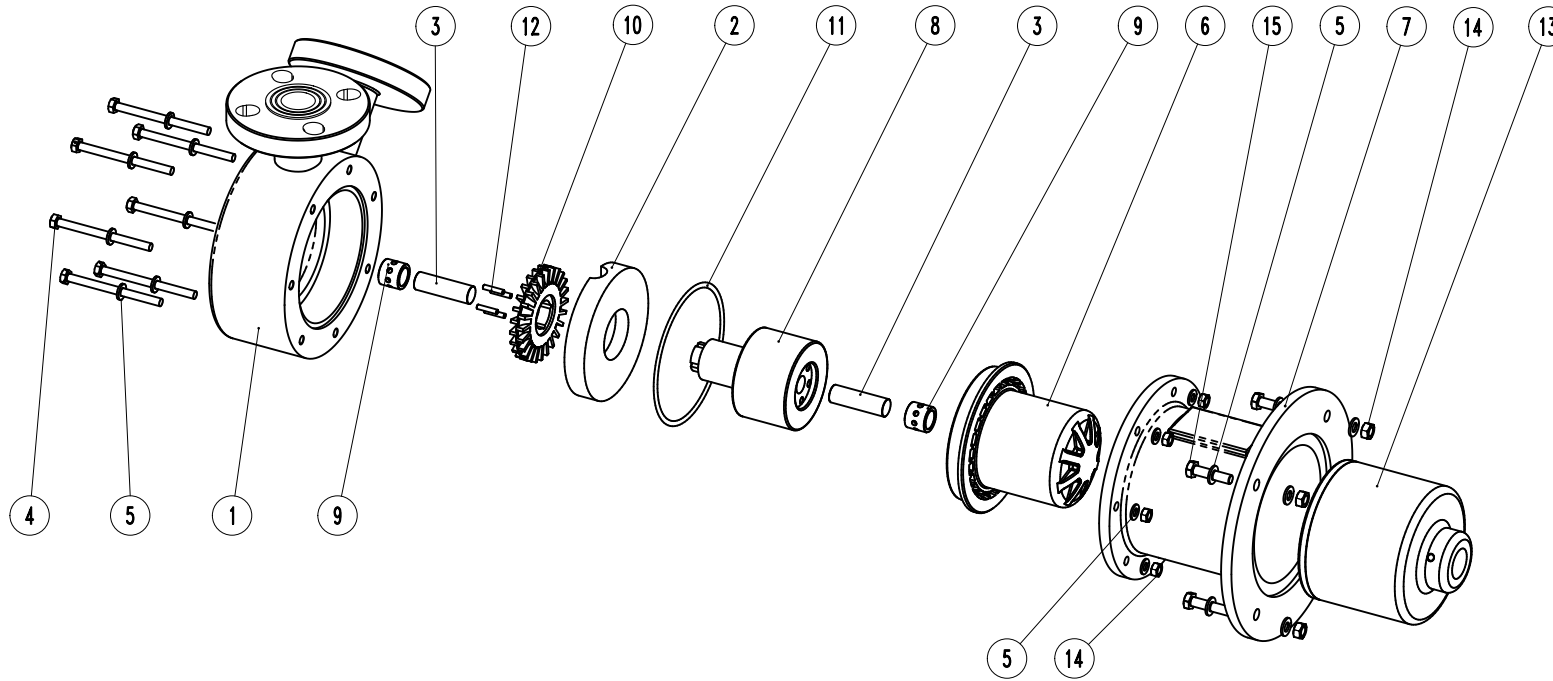

ITEM: Pump model: T MAG-P52 PVDF

# PART LIST

ITEM N°	CODE META	Description	Material	Q.ty	ITEM N°	CODE META	Description	Material	Q.ty
1	56220T1052VU	Pump Casing	PVDF	1	14	91620N06A2	Nut UNI5588 M6	A2-70	11
2	55120T1052V	Volute Ring	PVDF	1	15	91610TE630A2	Screw UNI24017 M6x30	A2-70	4
3	90010A01001	Front / Rear shaft	Al2o3	2					
4	91610TE670A2	Screw UNI24017 M6x70	A2-70	7					
5	91630N0612A2	Washer UNI6592 D.6x12	A2-70	22					
6	55610T1052V	Rear Casing	PVDF	1					
7	56120T105206D	Bracket	PP	1					
8	55820T1052AV	Internal Magnet	PVDF/NdFeB	1					
9	90310C201517	Bushing	PTFEC	2					
10	55710T1052V	Impeller	PVDF	1					
11	92910V9167	O-Ring 4362/BS239	VITON	1					
12	56610D030015V	Impeller Pins	PVDF	2					
13	55810T105206N	External magnet	A105/NdFeB	1					

Motor: IEC Gr71 B5  
 Port connection: Flanged  
 UNI EN1092-1 PN.10 / ANSI (ASA) B16.5 150#

- This drawing is for reference only

# EXPLODED VIEW

CODE: E 10401 Rev.:01

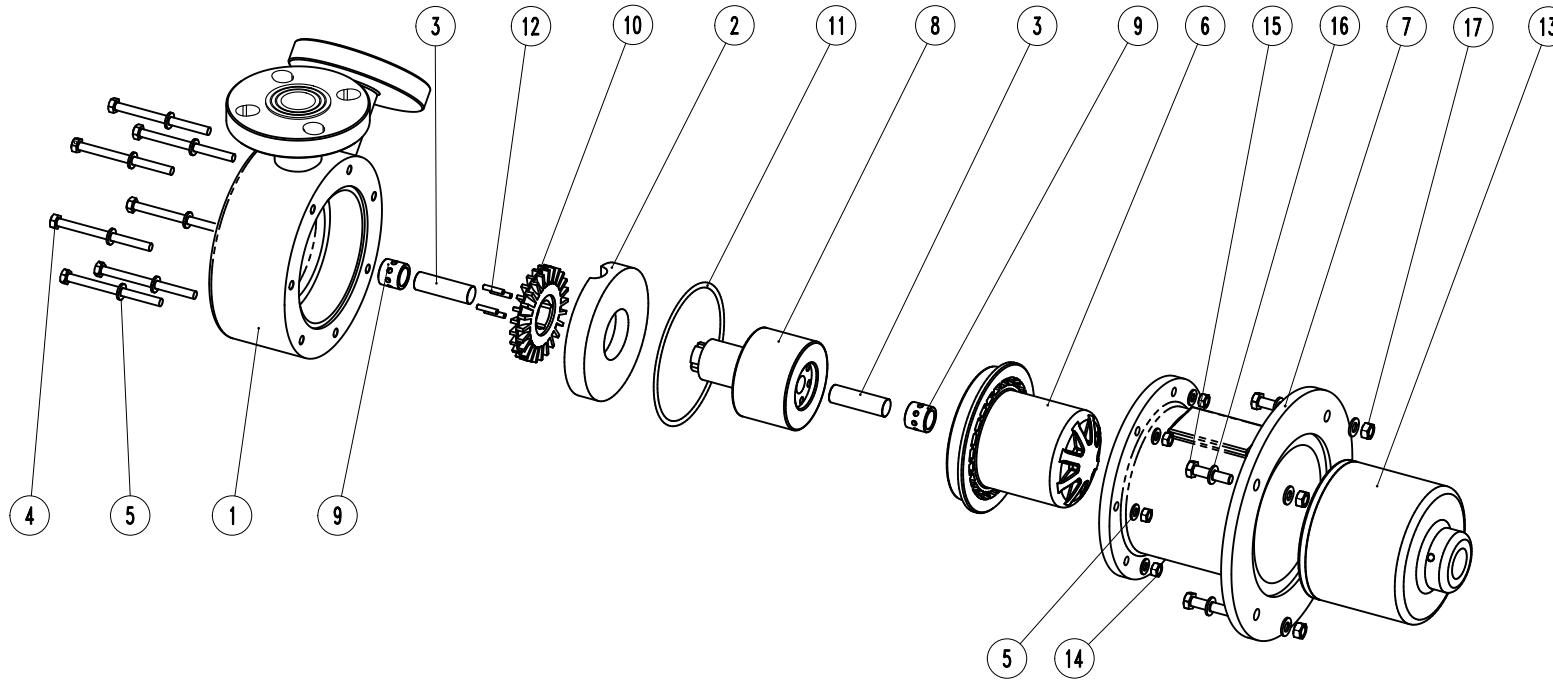

ITEM: Pump model: T MAG-P53 PP

# PART LIST

Motor: IEC Gr80 B5  
Port connection: Flanged

UNI EN1092-1 PN.10 / ANSI (ASA) B16.5 150#

ITEM N°	CODE META	Description	Material	Q.ty	ITEM N°	CODE META	Description	Material	Q.ty
1	56220T1053PU	Pump Casing	PP	1	14	91620N06A2	Nut UNI5588 M6	A2-70	7
2	55120T1053P	Volute Ring	PP	1	15	91610TE840A2	Screw UNI24017 M8x40	A2-70	4
3	90010A01001	Front / Rear shaft	Al2o3	2	16	91630N0816A2	Washer UNI6592 D.8x16	A2-70	8
4	91610TE690A2	Screw UNI24017 M6x90	A2-70	7	17	91620N08A2	Nut UNI5588 M8	A2-70	4
5	91630N0612A2	Washer UNI6592 D.6x12	A2-70	14					
6	55610T1072P	Rear Casing	PP FV10%	1					
7	56120T105308D	Bracket	PP	1					
8	55820T1053AP	Internal Magnet	PP/NdFeB	1					
9	90310C201517	Bushing	PTFEC	2					
10	55710T1053P	Impeller	PP	1					
11	92910E1044	O-Ring 4412/BS243	EPDM	1					
12	56610D035017V	Impeller Pins	PVDF	4					
13	55810T107208N	External magnet	A105/NdFeB	1					

- This drawing is for reference only

# EXPLODED VIEW

CODE: E 10402 Rev.:01

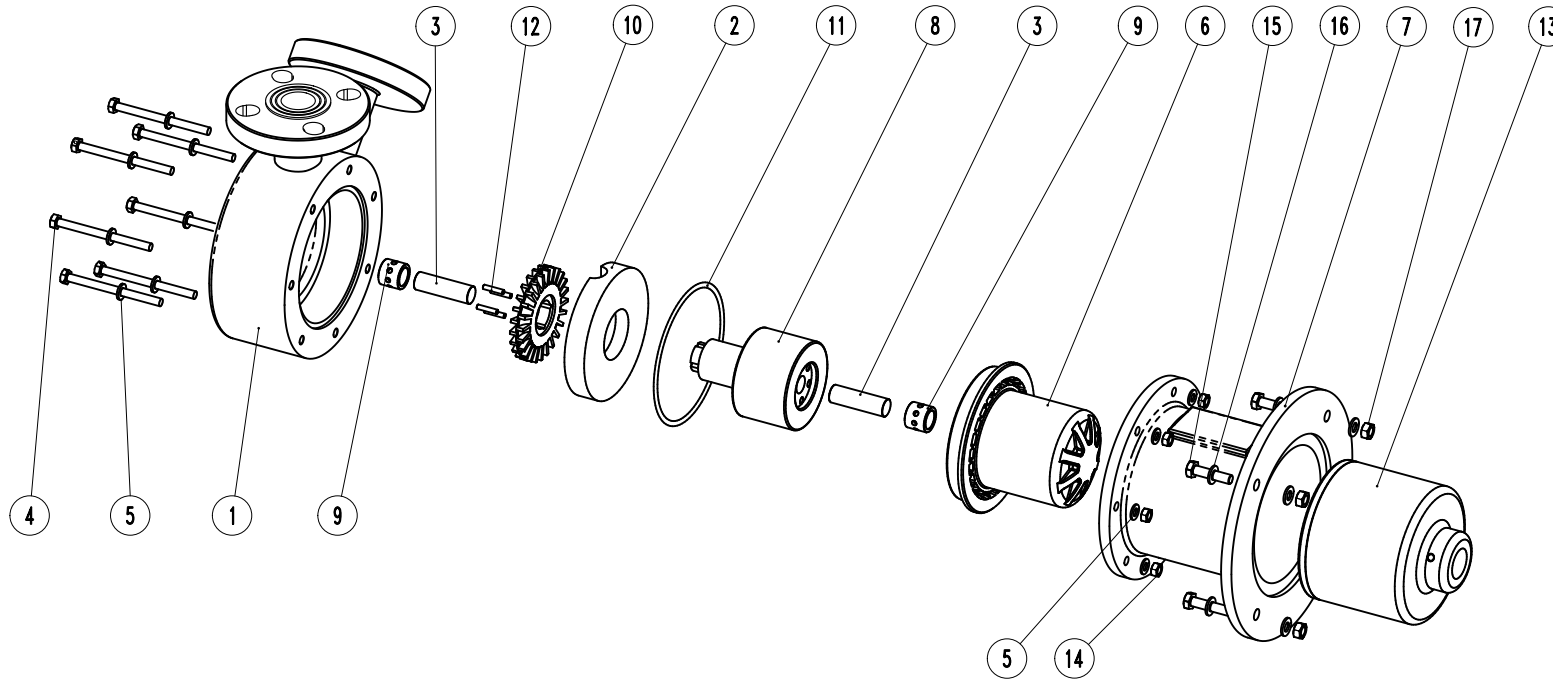

ITEM: Pump model: T MAG-P53 PVDF

# PART LIST

ITEM N°	CODE META	Description	Material	Q.ty	ITEM N°	CODE META	Description	Material	Q.ty
1	56220T1053VU	Pump Casing	PVDF	1	14	91620N06A2	Nut UNI5588 M6	A2-70	7
2	55120T1053V	Volute Ring	PVDF	1	15	91610TE840A2	Screw UNI24017 M8x40	A2-70	4
3	90010A01001	Front / Rear shaft	Al2o3	2	16	91630N0816A2	Washer UNI6592 D.8x16	A2-70	8
4	91610TE690A2	Screw UNI24017 M6x90	A2-70	7	17	91620N08A2	Nut UNI5588 M8	A2-70	4
5	91630N0612A2	Washer UNI6592 D.6x12	A2-70	14					
6	55610T1072V	Rear Casing	PVDF	1					
7	56120T105308D	Bracket	PP	1					
8	55820T1053AV	Internal Magnet	PVDF/NdFeB	1					
9	90310C201517	Bushing	PTFEC	2					
10	55710T1053V	Impeller	PVDF	1					
11	92910V1044	O-Ring 4412/BS243	Viton	1					
12	56610D035017V	Impeller Pins	PVDF	4					
13	55810T107208N	External magnet	A105/NdFeB	1					

Motor: IEC Gr80 B5  
 Port connection: Flanged  
 UNI EN1092-1 PN.10 / ANSI (ASA) B16.5 150#

- This drawing is for reference only



# EXPLODED VIEW

CODE: E 10403 Rev.:01

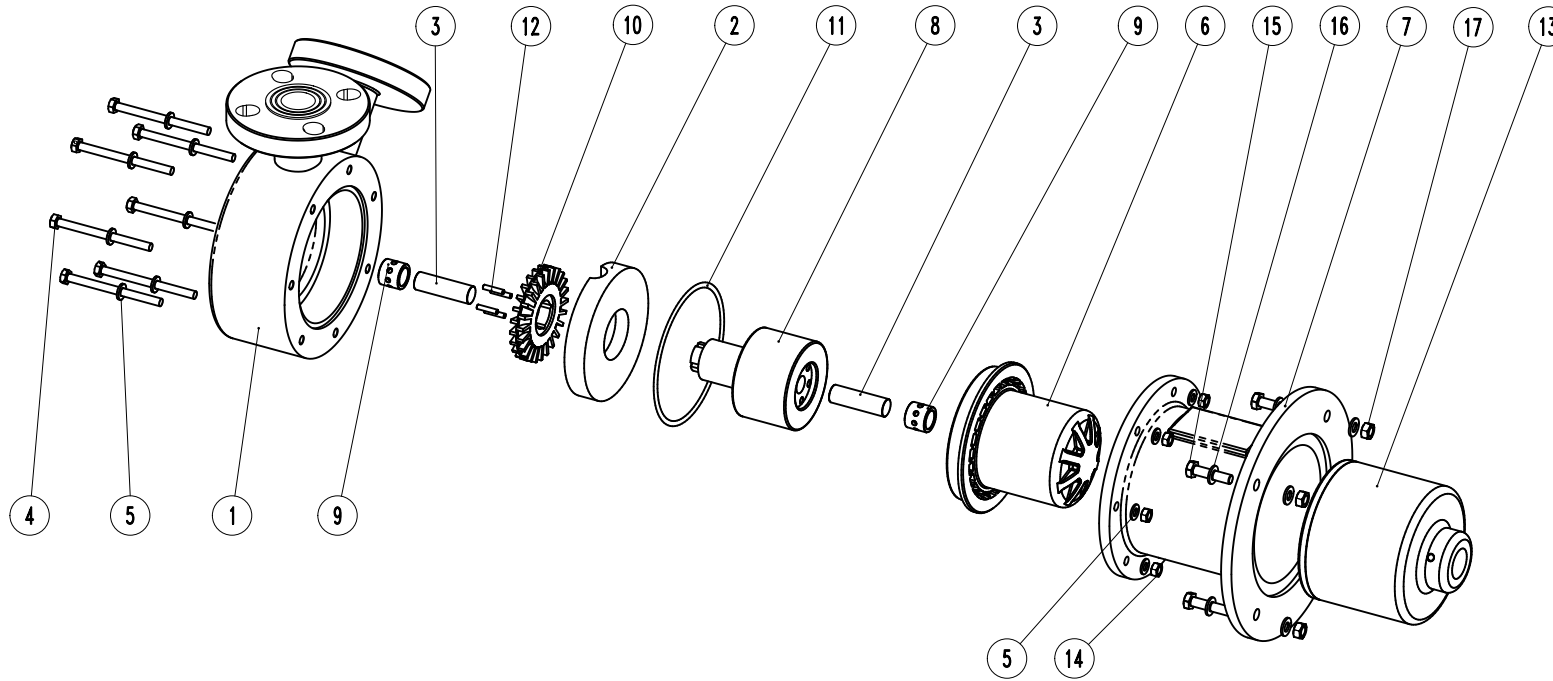

ITEM: Pump model: T MAG-P72 PP

# PART LIST

Motor: IEC Gr80 B5  
Port connection: Flanged

UNI EN1092-1 PN.10 / ANSI (ASA) B16.5 150#

ITEM N°	CODE META	Description	Material	Q.ty	ITEM N°	CODE META	Description	Material	Q.ty
1	56220T1072PU	Pump Casing	PP	1	14	91620N06A2	Nut UNI5588 M6	A2-70	7
2	55120T1072P	Volute Ring	PP	1	15	91610TE840A2	Screw UNI24017 M8x40	A2-70	4
3	90010A01001	Front / Rear shaft	Al2o3	2	16	91630N0816A2	Washer UNI6592 D.8x16	A2-70	8
4	91610TE690A2	Screw UNI24017 M6x90	A2-70	7	17	91620N08A2	Nut UNI5588 M8	A2-70	4
5	91630N0612A2	Washer UNI6592 D.6x12	A2-70	14					
6	55610T1072P	Rear Casing	PP FV10%	1					
7	56120T105308D	Bracket	PP	1					
8	55820T1072AP	Internal Magnet	PP/NdFeB	1					
9	90310C201517	Bushing	PTFEC	2					
10	55710T1072P	Impeller	PP	1					
11	92910E1044	O-Ring 4412/BS243	EPDM	1					
12	56610D035017V	Impeller Pins	PVDF	4					
13	55810T107208N	External magnet	A105/NdFeB	1					

- This drawing is for reference only

# EXPLODED VIEW

CODE: E 10404 Rev.:01

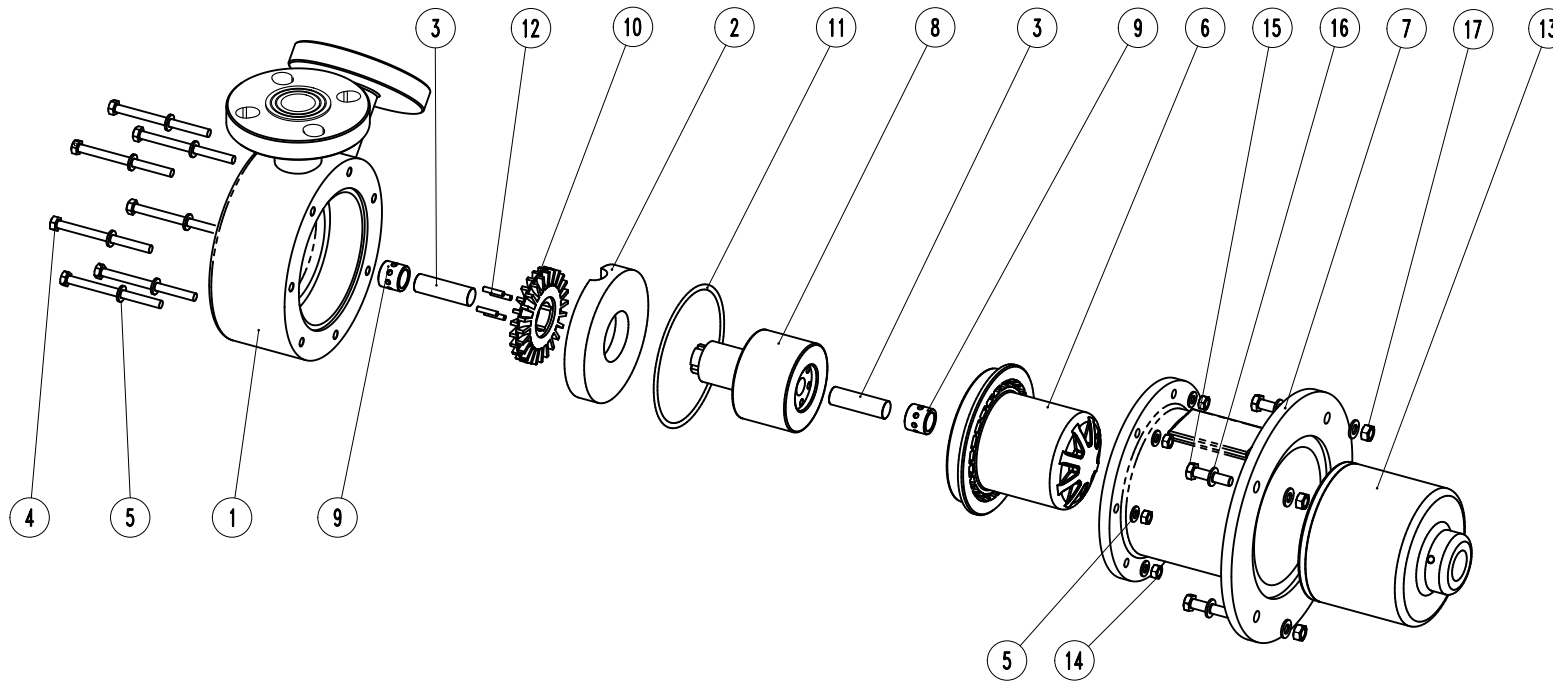

ITEM: Pump model: T MAG-P72 PVDF

# PART LIST

Motor: IEC Gr80 B5  
Port connection: Flanged

UNI EN1092-1 PN.10 / ANSI (ASA) B16.5 150#

ITEM N°	CODE META	Description	Material	Q.ty	ITEM N°	CODE META	Description	Material	Q.ty
1	56220T1072VU	Pump Casing	PVDF	1	14	91620N06A2	Nut UNI5588 M6	A2-70	7
2	55120T1072V	Volute Ring	PVDF	1	15	91610TE840A2	Screw UNI24017 M8x40	A2-70	4
3	90010A01001	Front / Rear shaft	Al2o3	2	16	91630N0816A2	Washer UNI6592 D.8x16	A2-70	8
4	91610TE690A2	Screw UNI24017 M6x90	A2-70	7	17	91620N08A2	Nut UNI5588 M8	A2-70	4
5	91630N0612A2	Washer UNI6592 D.6x12	A2-70	14					
6	55610T1072V	Rear Casing	PVDF	1					
7	56120T105308D	Bracket	PP	1					
8	55820T1072AV	Internal Magnet	PVDF/NdFeB	1					
9	90310C201517	Bushing	PTFEC	2					
10	55710T1072V	Impeller	PVDF	1					
11	92910V1044	O-Ring 4412/BS243	Viton	1					
12	56610D035017V	Impeller Pins	PVDF	4					
13	55810T107208N	External magnet	A105/NdFeB	1					

- This drawing is for reference only

# EXPLODED VIEW

CODE: E 10405 Rev.:01

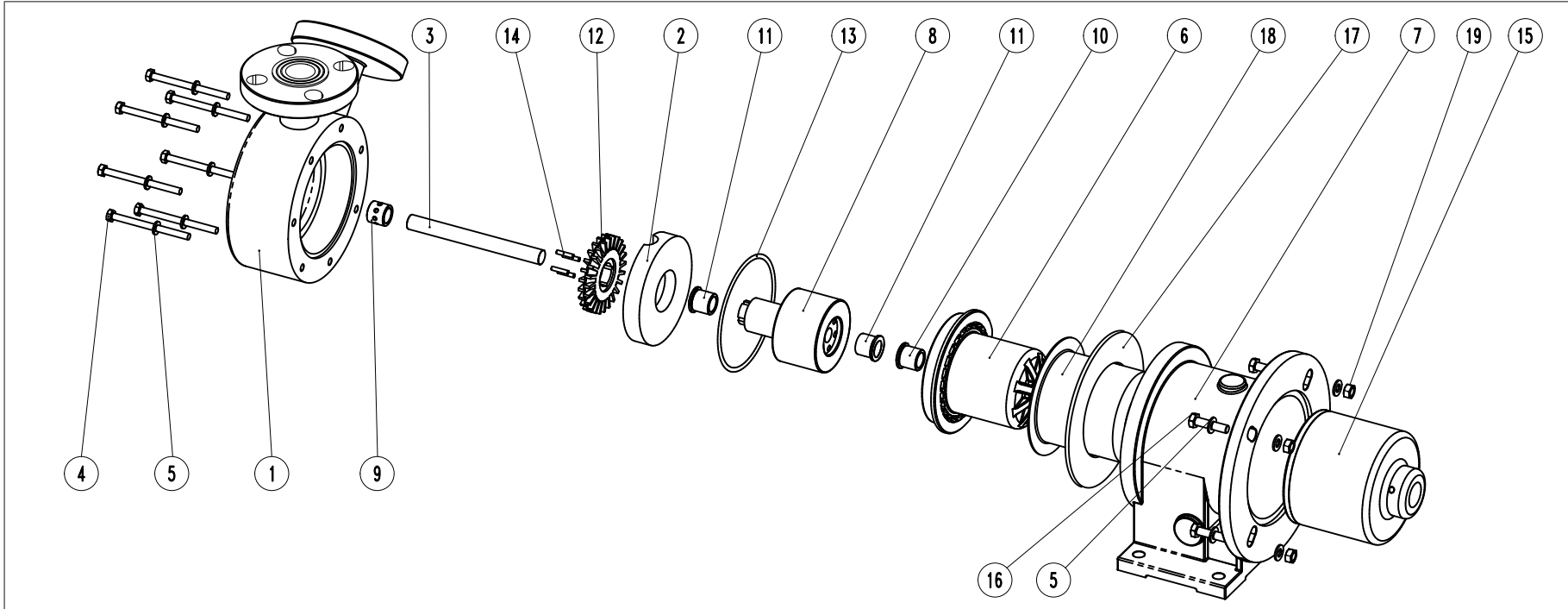

ITEM: Pump model: T MAG-P73 PP

# PART LIST

Motor: IEC Gr90 B5  
Port connection: Flanged

UNI EN1092-1 PN.10 / ANSI (ASA) B16.5 150#

ITEM N°	CODE META	Description	Material	Q.ty	ITEM N°	CODE META	Description	Material	Q.ty
1	56220T1073PU	Pump Casing	PP	1	14	56610D0050025V	Impeller Pins	PVDF	4
2	55120T1073P	Volute Ring	PP	1	15	55810T109210N	External magnet	A105/NdFeB	1
3	90010A02001T	Shaft	Al2o3	1	16	91610TE840A2	Screw UNI24017 M8x40	A2-70	4
4	91610TE890A2	Screw UNI24017 M8x90	A2-70	7	17	901501535924A	Reinforced Ring	AISI 304	1
5	91630N0816A2	Washer UNI6592 D.8x16	A2-70	15	18	93050T1092FC	Rear casing Armor	Carbon fiber	1
6	55610T1073P	Rear Casing	PP	1	19	91620N08A2	Nut UNI5588 M8	A2-70	4
7	56110C105010C	Bracket	WCB	1					
8	55820T1092AP	Internal Magnet	PP/NdFeB	1					
9	90310C242015T	Pump casing Bushing	PTFEC	1					
10	90310C242015	Rear casing Bushing	PTFEC	1					
11	90310C256030	Bushing	PTFEC	2					
12	55710T1073P	Impeller	PP	1					
13	92910E1456	O-Ring 4575/BS256	EPDM	1					

- This drawing is for reference only

# EXPLODED VIEW

CODE: E 10406 Rev.:01

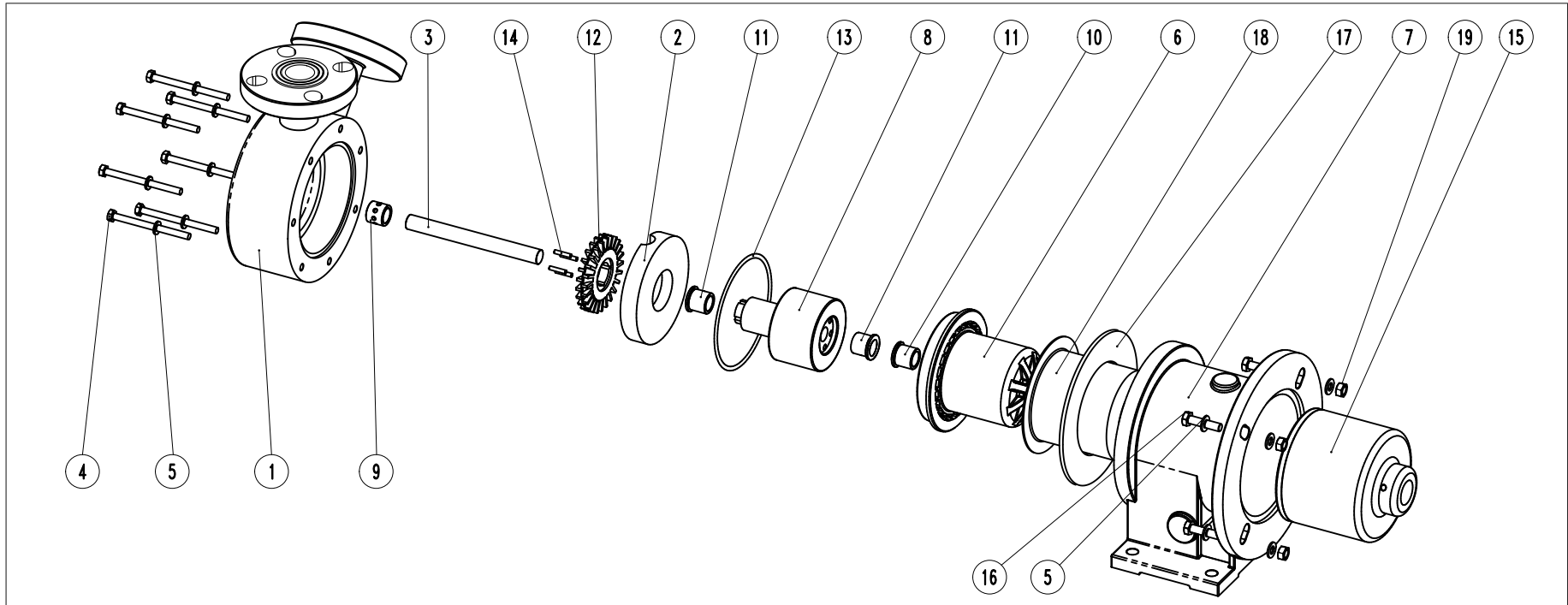

ITEM: Pump model: T MAG-P73 PVDF

# PART LIST

ITEM N°	CODE META	Description	Material	Q.ty	ITEM N°	CODE META	Description	Material	Q.ty
1	56220T1073VU	Pump Casing	PVDF	1	14	56610D0050025V	Impeller Pins	PVDF	4
2	55120T1073V	Volute Ring	PVDF	1	15	55810T109210N	External magnet	A105/NdFeB	1
3	90010A02001T	Shaft	Al2o3	1	16	91610TE840A2	Screw UNI24017 M8x40	A2-70	4
4	91610TE890A2	Screw UNI24017 M8x90	A2-70	7	17	901501535924A	Reinforced Ring	AISI 304	1
5	91630N0816A2	Washer UNI6592 D.8x16	A2-70	15	18	93050T1092FC	Rear casing Armor	Carbon fiber	1
6	55610T1073V	Rear Casing	PVDF	1	19	91620N08A2	Nut UNI5588 M8	A2-70	4
7	56110C105010C	Bracket	WCB	1					
8	55820T1092AV	Internal Magnet	PVDF/NdFeB	1					
9	90310C242015T	Pump casing Bushing	PTFEC	1					
10	90310C242015	Rear casing Bushing	PTFEC	1					
11	90310C256030	Bushing	PTFEC	2					
12	55710T1073V	Impeller	PVDF	1					
13	92910V1456	O-Ring 4575/BS256	Viton	1					

Motor: IEC Gr90 B5  
 Port connection: Flanged  
 UNI EN1092-1 PN.10 / ANSI (ASA) B16.5 150#

- This drawing is for reference only

# EXPLODED VIEW

CODE: E 10407 Rev.:01

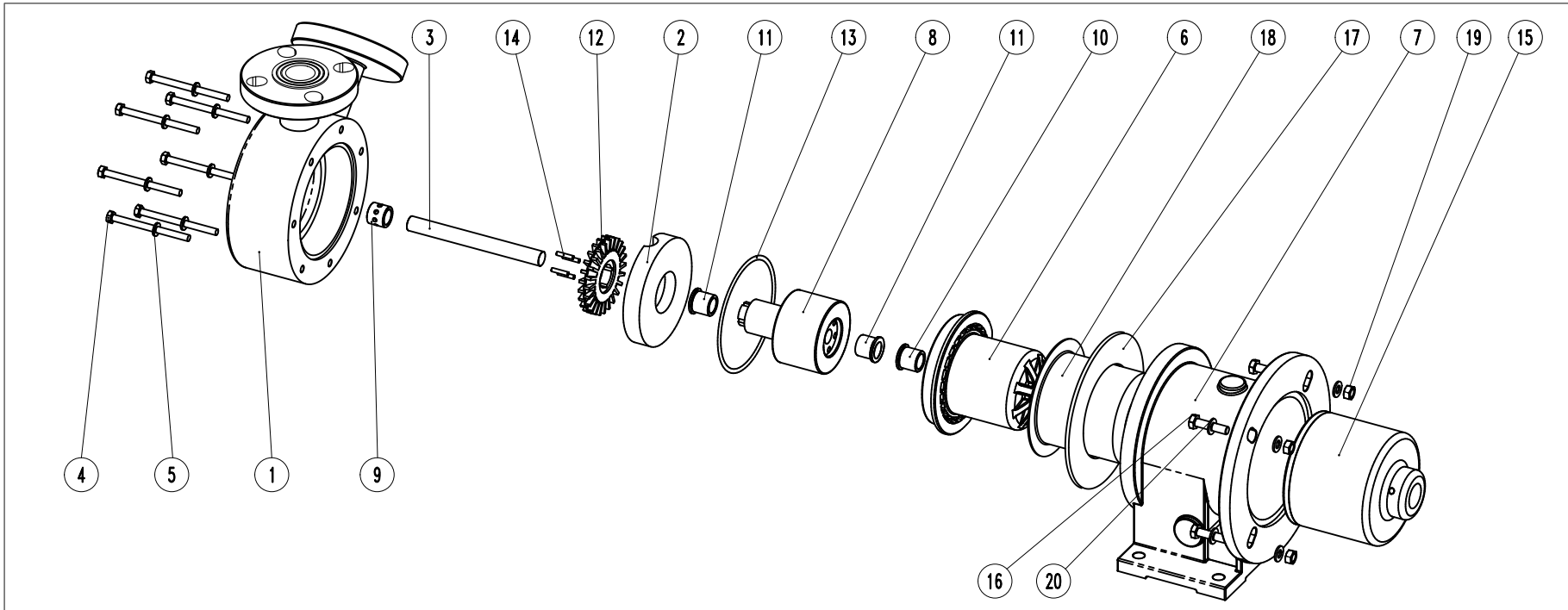

ITEM: Pump model: T MAG-P73 PP

# PART LIST

ITEM N°	CODE META	Description	Material	Q.ty	ITEM N°	CODE META	Description	Material	Q.ty
1	56220T1073PU	Pump Casing	PP	1	14	56610D0050025V	Impeller Pins	PVDF	4
2	55120T1073P	Volute Ring	PP	1	15	55810T109212N	External magnet	A105/NdFeB	1
3	90010A02001T	Shaft	Al2o3	1	16	91610TE1045A2	Screw UNI24017 M10x45	A2-70	4
4	91610TE890A2	Screw UNI24017 M8x90	A2-70	7	17	901501535924A	Reinforced Ring	AlSI 304	1
5	91630N0816A2	Washer UNI6592 D.8x16	A2-70	7	18	93050T1092FC	Rear casing Armor	Carbon fiber	1
6	55610T1073P	Rear Casing	PP	1	19	91620N10A2	Nut UNI5588 M10	A2-70	4
7	56110C10501214C	Bracket	WCB	1	20	91630N1020A2	Washer UNI6592 D.10x20	A2-70	8
8	55820T1092AP	Internal Magnet	PP/NdFeB	1					
9	90310C242015T	Pump casing Bushing	PTFEC	1					
10	90310C242015	Rear casing Bushing	PTFEC	1					
11	90310C256030	Bushing	PTFEC	2					
12	55710T1073P	Impeller	PP	1					
13	92910E1456	O-Ring 4575/BS256	EPDM	1					

Motor: IEC Gr100/112 B5  
 Port connection: Flanged  
 UNI EN1092-1 PN.10 / ANSI (ASA) B16.5 150#

- This drawing is for reference only

# EXPLODED VIEW

CODE: E 10408 Rev.:01

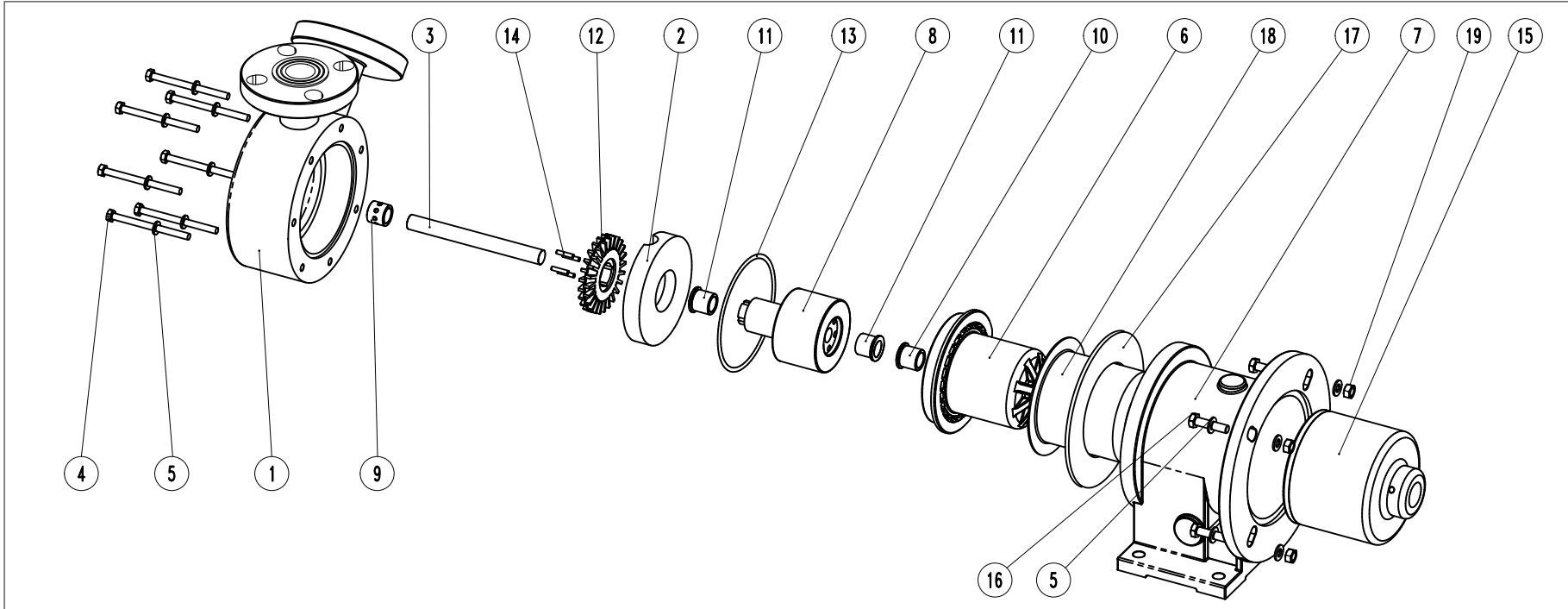

ITEM: Pump model: T MAG-P73 PVDF

# PART LIST

ITEM N°	CODE META	Description	Material	Q.ty	ITEM N°	CODE META	Description	Material	Q.ty
1	56220T1073VU	Pump Casing	PVDF	1	14	56610D0050025V	Impeller Pins	PVDF	4
2	55120T1073V	Volute Ring	PVDF	1	15	55810T109212N	External magnet	A105/NdFeB	1
3	90010A02001T	Shaft	Al2o3	1	16	91610TE840A2	Screw UNI24017 M8x40	A2-70	4
4	91610TE890A2	Screw UNI24017 M8x90	A2-70	7	17	901501535924A	Reinforced Ring	AISI 304	1
5	91630N0816A2	Washer UNI6592 D.8x16	A2-70	7	18	93050T1092FC	Rear casing Armor	Carbon fiber	1
6	55610T1073V	Rear Casing	PVDF	1	19	91620N08A2	Nut UNI5588 M8	A2-70	4
7	56110C10501214C	Bracket	WCB	1	20	91630N1020A2	Washer UNI6592 D.10x20	A2-70	8
8	55820T1092AV	Internal Magnet	PVDF/NdFeB	1					
9	90310C242015T	Pump casing Bushing	PTFEC	1					
10	90310C242015	Rear casing Bushing	PTFEC	1					
11	90310C256030	Bushing	PTFEC	2					
12	55710T1073V	Impeller	PVDF	1					
13	92910V1456	O-Ring 4575/BS256	Viton	1					

Motor: IEC Gr100/112 B5  
 Port connection: Flanged  
 UNI EN1092-1 PN.10 / ANSI (ASA) B16.5 150#

- This drawing is for reference only

# EXPLODED VIEW

CODE: E 10409 Rev.:01

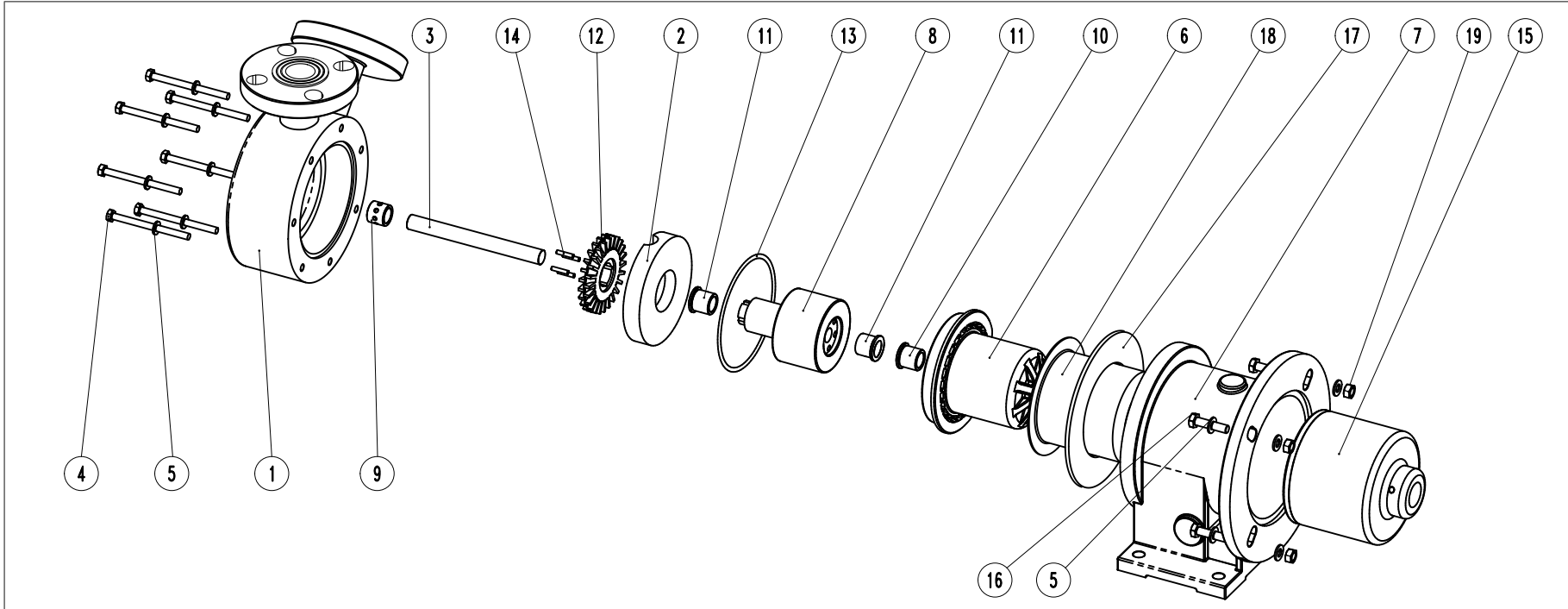

ITEM: Pump model: T MAG-P92 PP

# PART LIST

Motor: IEC Gr90 B5  
Port connection: Flanged

UNI EN1092-1 PN.10 / ANSI (ASA) B16.5 150#

ITEM N°	CODE META	Description	Material	Q.ty	ITEM N°	CODE META	Description	Material	Q.ty
1	56220T1092PU	Pump Casing	PP	1	14	56610D0050025V	Impeller Pins	PVDF	4
2	55120T1092P	Volute Ring	PP	1	15	55810T109210N	External magnet	A105/NdFeB	1
3	90010A02001T	Shaft	Al2o3	1	16	91610TE840A2	Screw UNI24017 M8x40	A2-70	4
4	91610TE890A2	Screw UNI24017 M8x90	A2-70	7	17	901501535924A	Reinforced Ring	ANSI 304	1
5	91630N0816A2	Washer UNI6592 D.8x16	A2-70	15	18	93050T1092FC	Rear casing Armor	Carbon fiber	1
6	55610T1073P	Rear Casing	PP	1	19	91620N08A2	Nut UNI5588 M8	A2-70	4
7	56110C105010C	Bracket	WCB	1					
8	55820T1092AP	Internal Magnet	PP/NdFeB	1					
9	90310C242015T	Pump casing Bushing	PTFEC	1					
10	90310C242015	Rear casing Bushing	PTFEC	1					
11	90310C256030	Bushing	PTFEC	2					
12	55710T1092P	Impeller	PP	1					
13	92910E1456	O-Ring 4575/BS256	EPDM	1					

- This drawing is for reference only

# EXPLODED VIEW

CODE: E 10410 Rev.:01

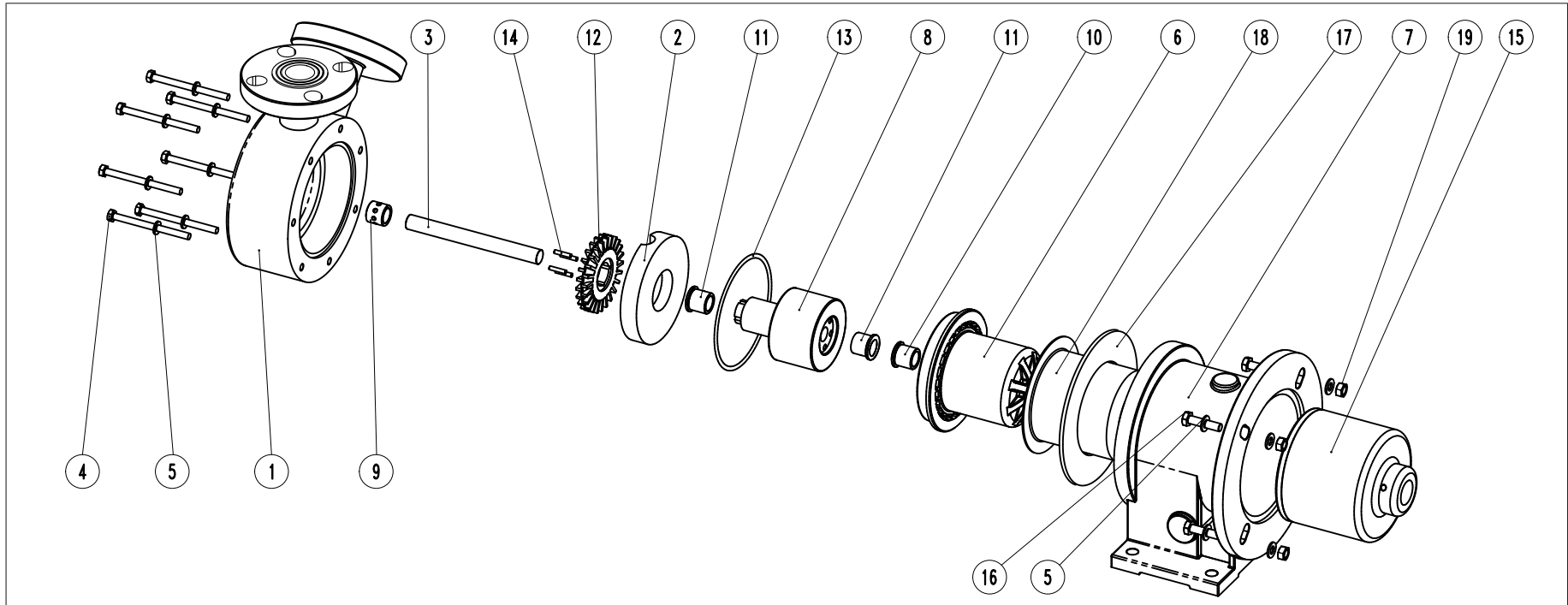

ITEM: Pump model: T MAG-P92 PVDF

# PART LIST

ITEM N°	CODE META	Description	Material	Q.ty	ITEM N°	CODE META	Description	Material	Q.ty
1	56220T1092VU	Pump Casing	PVDF	1	14	56610D0050025V	Impeller Pins	PVDF	4
2	55120T1092V	Volute Ring	PVDF	1	15	55810T109210N	External magnet	A105/NdFeB	1
3	90010A02001T	Shaft	Al2o3	1	16	91610TE840A2	Screw UNI24017 M8x40	A2-70	4
4	91610TE890A2	Screw UNI24017 M8x90	A2-70	7	17	901501535924A	Reinforced Ring	AISI 304	1
5	91630N0816A2	Washer UNI6592 D.8x16	A2-70	15	18	93050T1092FC	Rear casing Armor	Carbon fiber	1
6	55610T1073V	Rear Casing	PVDF	1	19	91620N08A2	Nut UNI5588 M8	A2-70	4
7	56110C105010C	Bracket	WCB	1					
8	55820T1092AV	Internal Magnet	PVDF/NdFeB	1					
9	90310C242015T	Pump casing Bushing	PTFEC	1					
10	90310C242015	Rear casing Bushing	PTFEC	1					
11	90310C256030	Bushing	PTFEC	2					
12	55710T1092V	Impeller	PVDF	1					
13	92910V1456	O-Ring 4575/BS256	Viton	1					

Motor: IEC Gr90 B5  
 Port connection: Flanged  
 UNI EN1092-1 PN.10 / ANSI (ASA) B16.5 150#

- This drawing is for reference only



# EXPLODED VIEW

CODE: E 10411 Rev.:01

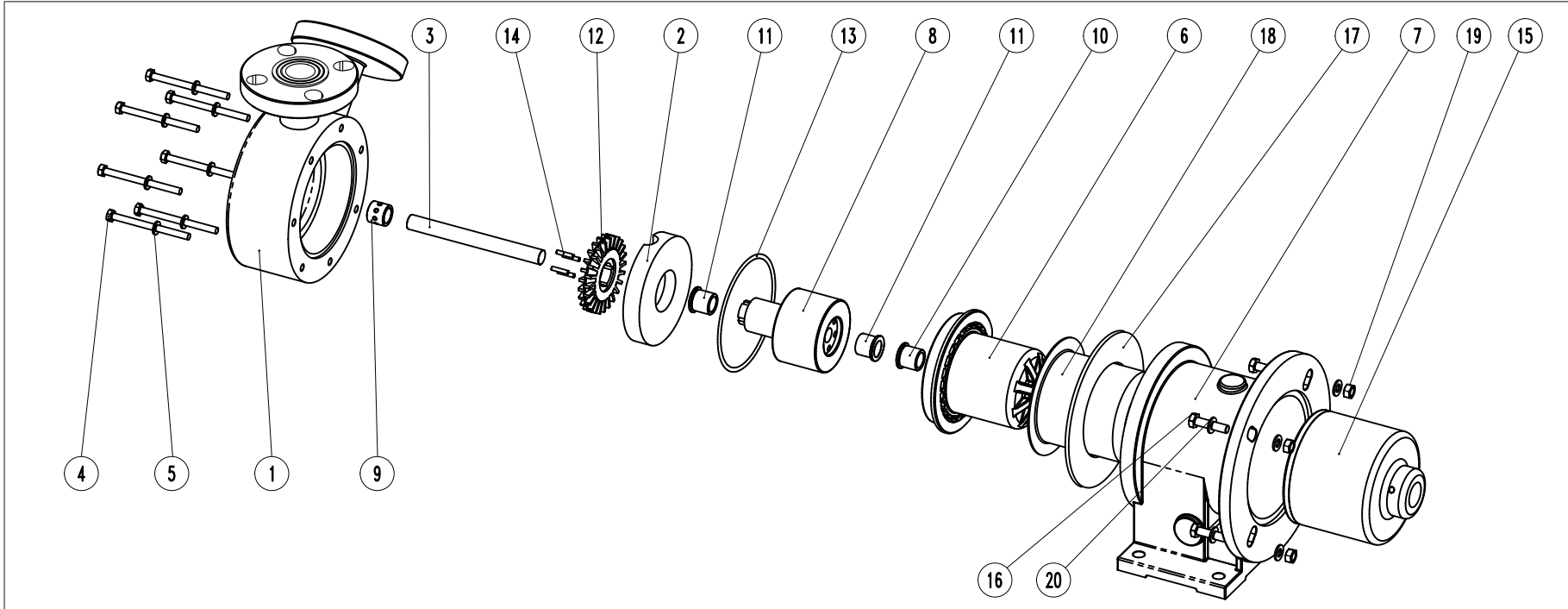

ITEM: Pump model: T MAG-P93 PP

# PART LIST

ITEM N°	CODE META	Description	Material	Q.ty	ITEM N°	CODE META	Description	Material	Q.ty
1	56220T1092PU	Pump Casing	PP	1	14	56610D0050025V	Impeller Pins	PVDF	4
2	55120T1092P	Volute Ring	PP	1	15	55810T109312N	External magnet	A105/NdFeB	1
3	90010A02001T	Shaft	Al2o3	1	16	91610TE1045A2	Screw UNI24017 M10x45	A2-70	4
4	91610TE890A2	Screw UNI24017 M8x90	A2-70	7	17	901501535924A	Reinforced Ring	AlSI 304	1
5	91630N0816A2	Washer UNI6592 D.8x16	A2-70	7	18	93050T1092FC	Rear casing Armor	Carbon fiber	1
6	55610T1073P	Rear Casing	PP	1	19	91620N10A2	Nut UNI5588 M10	A2-70	4
7	56110C10501214C	Bracket	WCB	1	20	91630N1020A2	Washer UNI6592 D.10x20	A2-70	8
8	55820T1093AP	Internal Magnet	PP/NdFeB	1					
9	90310C242015T	Pump casing Bushing	PTFEC	1					
10	90310C242015	Rear casing Bushing	PTFEC	1					
11	90310C256030	Bushing	PTFEC	2					
12	55710T1092P	Impeller	PP	1					
13	92910E1456	O-Ring 4575/BS256	EPDM	1					

Motor: IEC Gr100-112 B5  
 Port connection: Flanged  
 UNI EN1092-1 PN.10 / ANSI (ASA) B16.5 150#

- This drawing is for reference only

# EXPLODED VIEW

CODE: E 10412 Rev.:01

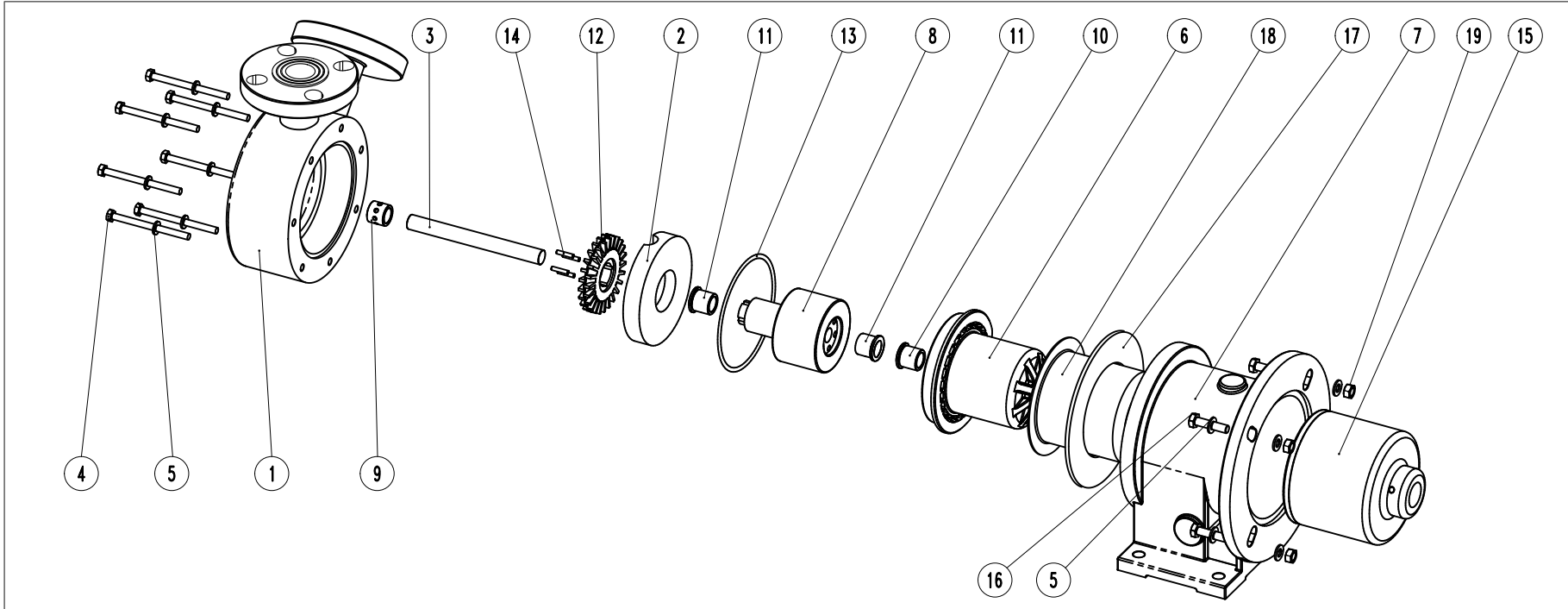

ITEM: Pump model: T MAG-P93 PVDF

# PART LIST

Motor: IEC Gr100-112 B5  
Port connection: Flanged

UNI EN1092-1 PN.10 / ANSI (ASA) B16.5 150#

ITEM N°	CODE META	Description	Material	Q.ty	ITEM N°	CODE META	Description	Material	Q.ty
1	56220T1092VU	Pump Casing	PVDF	1	14	56610D0050025V	Impeller Pins	PVDF	4
2	55120T1092V	Volute Ring	PVDF	1	15	55810T109312N	External magnet	A105/NdFeB	1
3	90010A02001T	Shaft	Al2o3	1	16	91610TE1045A2	Screw UNI24017 M10x45	A2-70	4
4	91610TE890A2	Screw UNI24017 M8x90	A2-70	7	17	901501535924A	Reinforced Ring	ANSI 304	1
5	91630N0816A2	Washer UNI6592 D.8x16	A2-70	7	18	93050T1092FC	Rear casing Armor	Carbon fiber	1
6	55610T1073V	Rear Casing	PVDF	1	19	91620N10A2	Nut UNI5588 M10	A2-70	4
7	56110C10501214C	Bracket	WCB	1	5	91630N1020A2	Washer UNI6592 D.10x20	A2-70	8
8	55820T1093AV	Internal Magnet	PVDF/NdFeB	1					
9	90310C242015T	Pump casing Bushing	PTFEC	1					
10	90310C242015	Rear casing Bushing	PTFEC	1					
11	90310C256030	Bushing	PTFEC	2					
12	55710T1092V	Impeller	PVDF	1					
13	92910V1456	O-Ring 4575/BS256	Viton	1					

- This drawing is for reference only

# EXPLODED VIEW

CODE: E 10413 Rev.:02

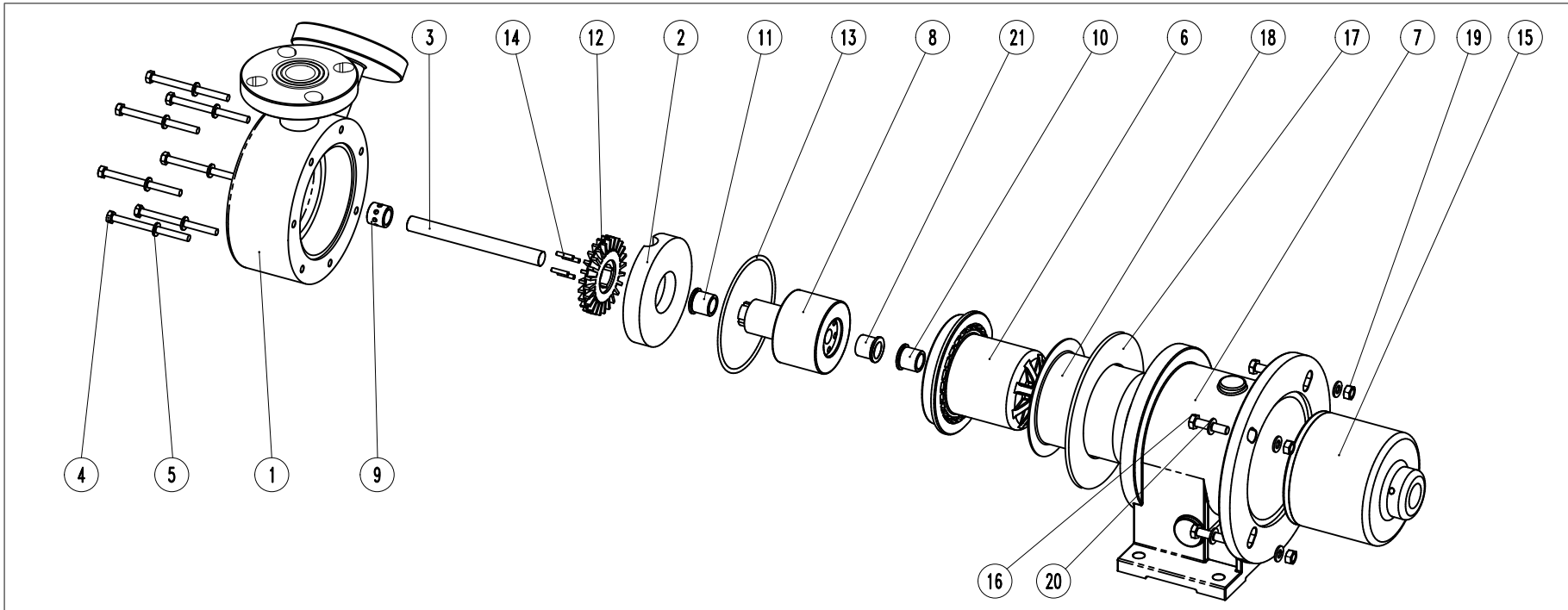

ITEM: Pump model: T MAG-P122 PP

# PART LIST

ITEM N°	CODE META	Description	Material	Q.ty	ITEM N°	CODE META	Description	Material	Q.ty
1	56220T1122PU	Pump Casing	PP	1	14	56610D100028V	Impeller Pins	PVDF	4
2	55120T1122P	Volute Ring	PP	1	15	55810T112212NN	External magnet	A105/NdFeB	1
3	90010A03001T	Shaft	Al2o3	1	16	91610TE1045A2	Screw UNI24017 M10x45	A2-70	4
4	91610TE8100A2	Screw UNI24017 M8x100	A2-70	7	17	9015018751254A	Reinforced Ring	AlSI 304	1
5	91630N0816A2	Washer UNI6592 D.8x16	A2-70	7	18	93050T1122FC	Rear casing Armor	Carbon fiber	1
6	55610C1080P	Rear Casing	PP	1	19	91620N10A2	Nut UNI5588 M10	A2-70	4
7	56110C10651214C	Bracket	WCB	1	20	91630N01020A2	Washer UNI6592 D.10x20	A2-70	8
8	55820T1122ANP	Internal Magnet	PP/NdFeB	1	21	90310C291558	Rear Bushing	PTFEC	1
9	90310C242015T	Pump casing Bushing	PTFEC	1					
10	90310C033025N	Rear casing Bushing	PTFEC	1					
11	90310C033045	Front Bushing	PTFEC	1					
12	55710T1122P	Impeller	PP	1					
13	92910E1667	O-Ring 228/BS628	EPDM	1					

Motor: IEC Gr100-112 B5  
 Port connection: Flanged  
 UNI EN1092-1 PN.10 / ANSI (ASA) B16.5 150#

- This drawing is for reference only

# EXPLODED VIEW

CODE: E 10414 Rev.:02

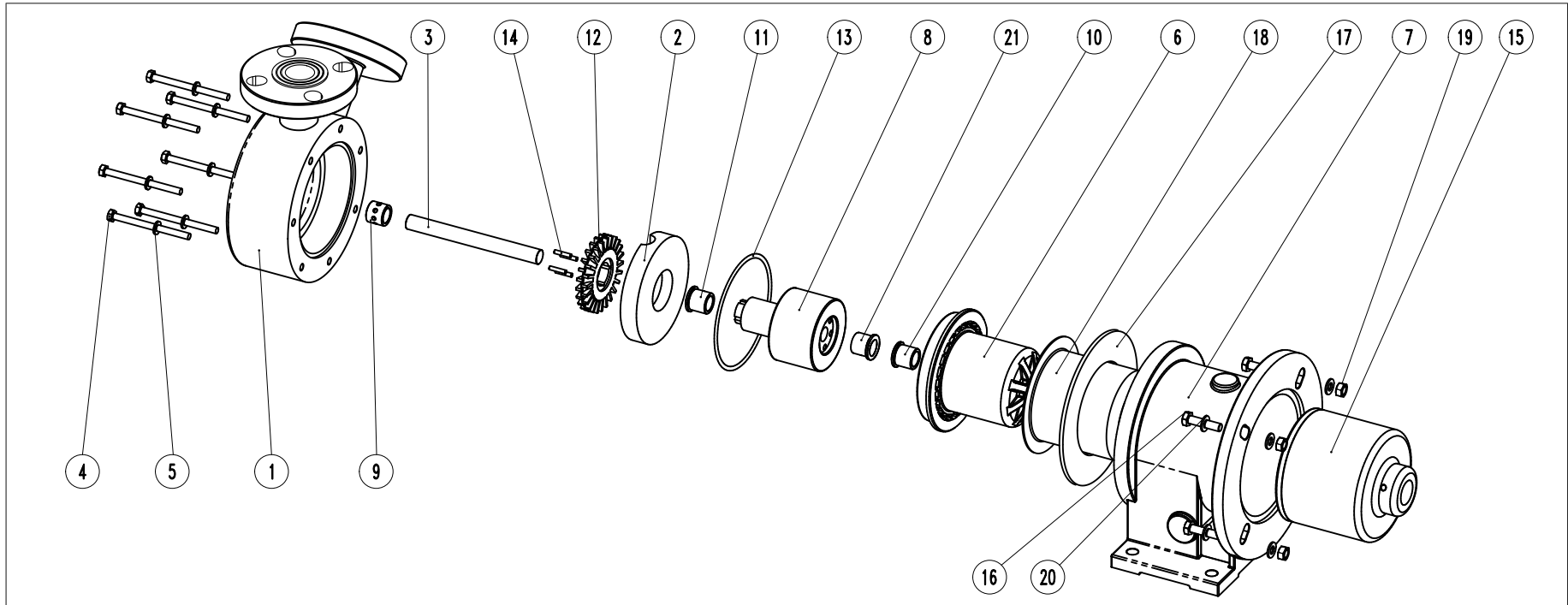

ITEM: Pump model: T MAG-P122 PVDF

# PART LIST

ITEM N°	CODE META	Description	Material	Q.ty	ITEM N°	CODE META	Description	Material	Q.ty
1	56220T1122VU	Pump Casing	PVDF	1	14	56610D100028V	Impeller Pins	PVDF	4
2	55120T1122V	Volute Ring	PVDF	1	15	55810T112212NN	External magnet	A105/NdFeB	1
3	90010A03001T	Shaft	Al2o3	1	16	91610TE1045A2	Screw UNI24017 M10x45	A2-70	4
4	91610TE8100A2	Screw UNI24017 M8x100	A2-70	7	17	9015018751254A	Reinforced Ring	AlSI 304	1
5	91630N0816A2	Washer UNI6592 D.8x16	A2-70	7	18	93050T1122FC	Rear casing Armor	Carbon fiber	1
6	55610C1080V	Rear Casing	PVDF	1	19	91620N10A2	Nut UNI5588 M10	A2-70	4
7	56110C10651214C	Bracket	WCB	1	20	91630N01020A2	Washer UNI6592 D.10x20	A2-70	8
8	55820T1122ANV	Internal Magnet	PVDF/NdFeB	1	21	90310C291558	Rear Bushing	PTFEC	1
9	90310C242015T	Pump casing Bushing	PTFEC	1					
10	90310C033025N	Rear casing Bushing	PTFEC	1					
11	90310C033045	Front Bushing	PTFEC	1					
12	55710T1122V	Impeller	PVDF	1					
13	92910V1667	O-Ring 228/BS628	Viton	1					

Motor: IEC Gr100-112 B5  
 Port connection: Flanged  
 UNI EN1092-1 PN.10 / ANSI (ASA) B16.5 150#

- This drawing is for reference only

# EXPLODED VIEW

CODE: E 10415 Rev.:02

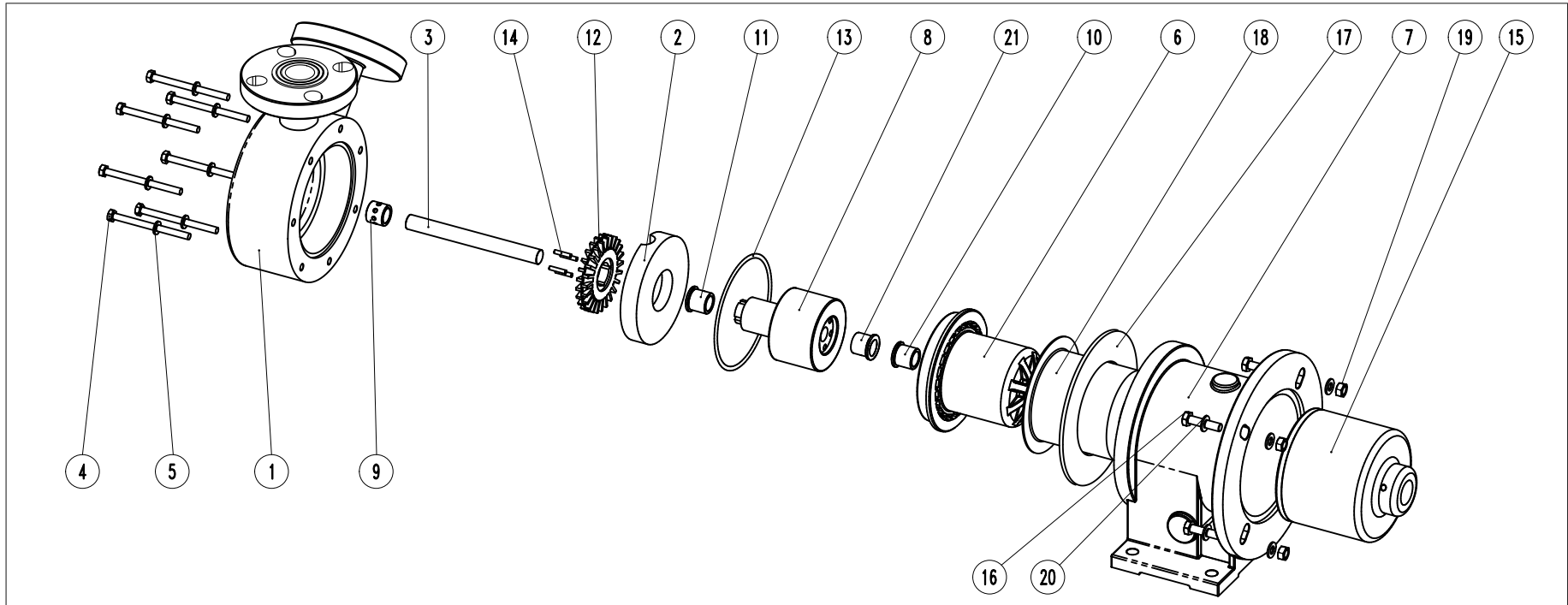

ITEM: Pump model: T MAG-P123 PP

# PART LIST

ITEM N°	CODE META	Description	Material	Q.ty	ITEM N°	CODE META	Description	Material	Q.ty
1	56220T1122PU	Pump Casing	PP	1	14	56610D100028V	Impeller Pins	PVDF	4
2	55120T1122P	Volute Ring	PP	1	15	55810T112216NN	External magnet	A105/NdFeB	1
3	90010A03001T	Shaft	Al2o3	1	16	91610TE1045A2	Screw UNI24017 M10x45	A2-70	4
4	91610TE8100A2	Screw UNI24017 M8x100	A2-70	7	17	9015018751254A	Reinforced Ring	AlSI 304	1
5	91630N0816A2	Washer UNI6592 D.8x16	A2-70	7	18	93050T1122FC	Rear casing Armor	Carbon fiber	1
6	55610C1080P	Rear Casing	PP	1	19	91620N10A2	Nut UNI5588 M10	A2-70	4
7	56110C106516C	Bracket	WCB	1	20	91630N01020A2	Washer UNI6592 D.10x20	A2-70	8
8	55820T1122ANP	Internal Magnet	PP/NdFeB	1	21	90310C291558	Rear Bushing	PTFEC	1
9	90310C242015T	Pump casing Bushing	PTFEC	1					
10	90310C033025N	Rear casing Bushing	PTFEC	1					
11	90310C033045	Front Bushing	PTFEC	1					
12	55710T1122P	Impeller	PP	1					
13	92910E1667	O-Ring 228/BS628	EPDM	1					

Motor: IEC Gr132 B5  
 Port connection: Flanged  
 UNI EN1092-1 PN.10 / ANSI (ASA) B16.5 150#

- This drawing is for reference only

# EXPLODED VIEW

CODE: E 10416 Rev.:02

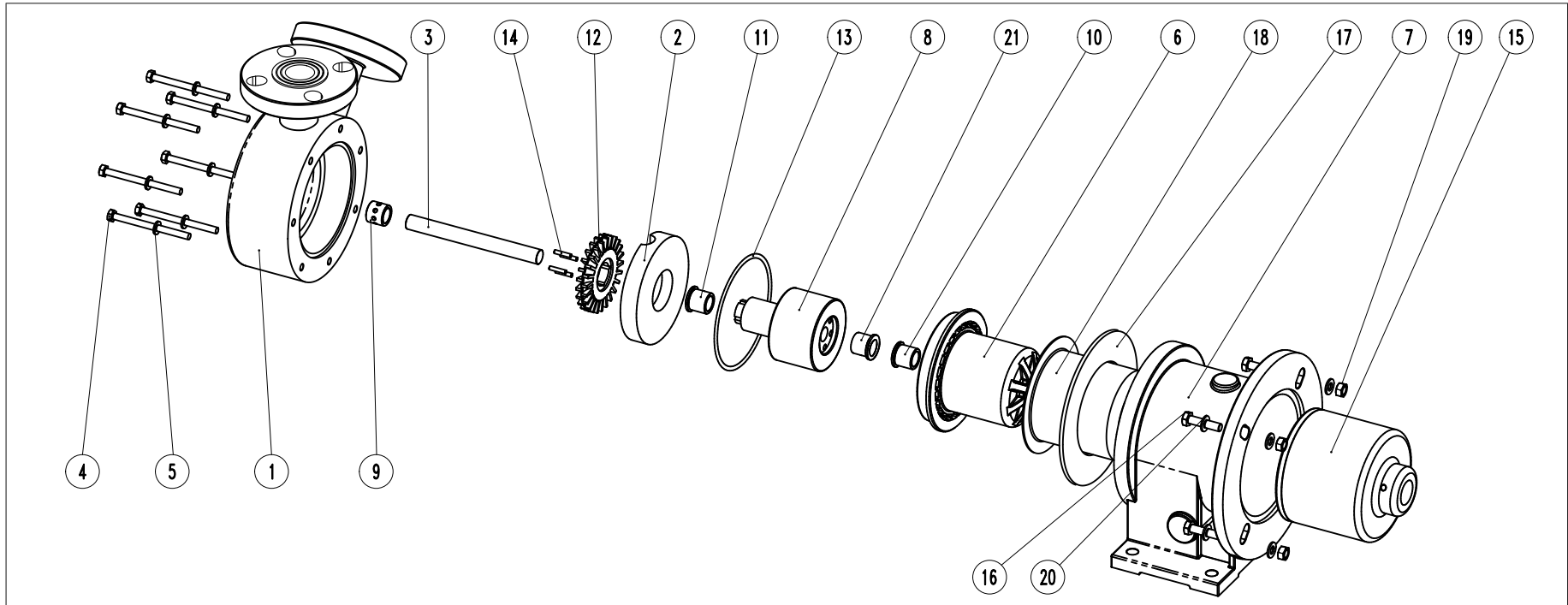

ITEM: Pump model: T MAG-P123 PVDF

# PART LIST

ITEM N°	CODE META	Description	Material	Q.ty	ITEM N°	CODE META	Description	Material	Q.ty
1	56220T1122VU	Pump Casing	PVDF	1	14	56610D100028V	Impeller Pins	PVDF	4
2	55120T1122V	Volute Ring	PVDF	1	15	55810T112216NN	External magnet	A105/NdFeB	1
3	90010A03001T	Shaft	Al2o3	1	16	91610TE1045A2	Screw UNI24017 M10x45	A2-70	4
4	91610TE8100A2	Screw UNI24017 M8x100	A2-70	7	17	9015018751254A	Reinforced Ring	AlSi 304	1
5	91630N0816A2	Washer UNI6592 D.8x16	A2-70	7	18	93050T1122FC	Rear casing Armor	Carbon fiber	1
6	55610C1080V	Rear Casing	PVDF	1	19	91620N10A2	Nut UNI5588 M10	A2-70	4
7	56110C106516C	Bracket	WCB	1	20	91630N01020A2	Washer UNI6592 D.10x20	A2-70	8
8	55820T1122ANV	Internal Magnet	PVDF/NdFeB	1	21	90310C291558	Rear Bushing	PTFEC	1
9	90310C242015T	Pump casing Bushing	PTFEC	1					
10	90310C033025N	Rear casing Bushing	PTFEC	1					
11	90310C033045	Front Bushing	PTFEC	1					
12	55710T1122V	Impeller	PVDF	1					
13	92910V1667	O-Ring 228/BS628	Viton	1					

Motor: IEC Gr132 B5  
 Port connection: Flanged  
 UNI EN1092-1 PN.10 / ANSI (ASA) B16.5 150#

- This drawing is for reference only

# EXPLODED VIEW

CODE: E 10417 Rev.:02

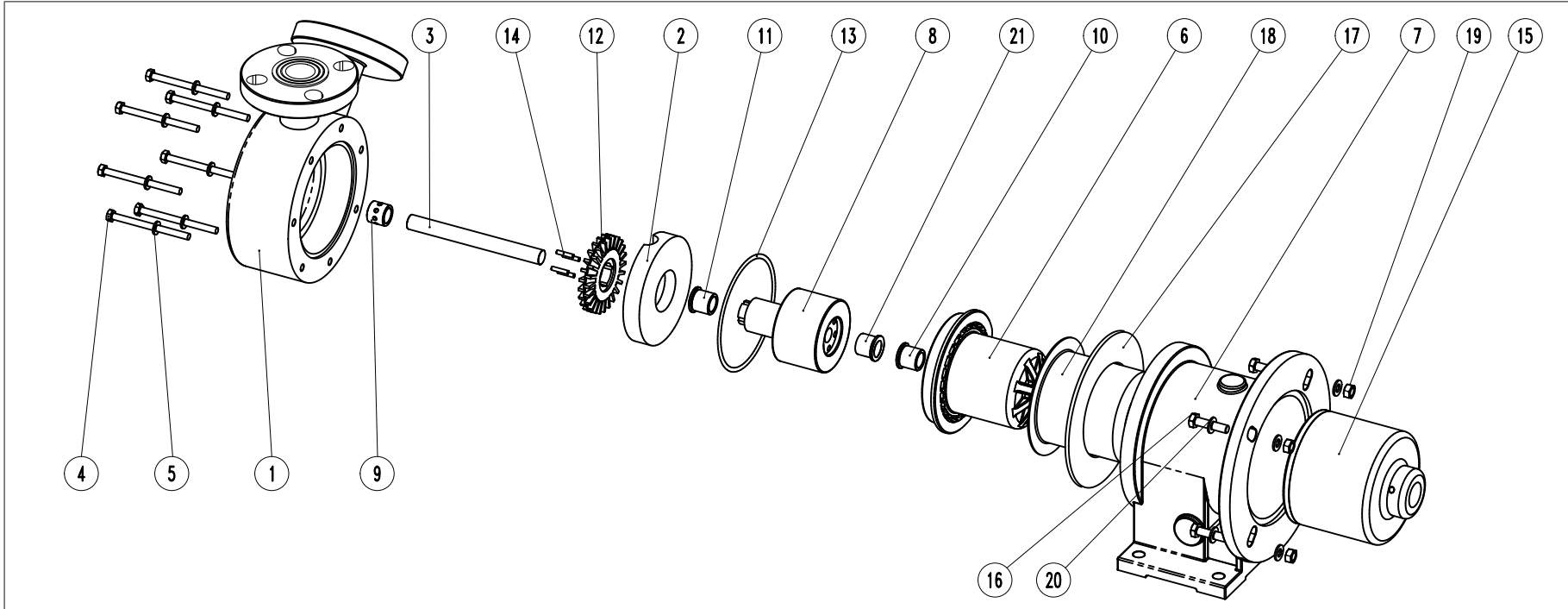

ITEM: Pump model: T MAG-P160 PP

# PART LIST

Motor: IEC Gr132 B5  
Port connection: Flanged

UNI EN1092-1 PN.10 / ANSI (ASA) B16.5 150#

ITEM N°	CODE META	Description	Material	Q.ty	ITEM N°	CODE META	Description	Material	Q.ty
1	56220T1160PU	Pump Casing	PP	1	14	56610D100028V	Impeller Pins	PVDF	4
2	55120T1160P	Volute Ring	PP	1	15	55810T112216NN	External magnet	A105/NdFeB	1
3	90010A03001T	Shaft	Al2o3	1	16	91610TE1045A2	Screw UNI24017 M10x45	A2-70	4
4	91610TE8100A2	Screw UNI24017 M8x100	A2-70	7	17	9015018751254A	Reinforced Ring	ANSI 304	1
5	91630N0816A2	Washer UNI6592 D.8x16	A2-70	7	18	93050T1122FC	Rear casing Armor	Carbon fiber	1
6	55610C1080P	Rear Casing	PP	1	19	91620N10A2	Nut UNI5588 M10	A2-70	4
7	56110C106516C	Bracket	WCB	1	20	91630N01020A2	Washer UNI6592 D.10x20	A2-70	8
8	55820T1122ANP	Internal Magnet	PP/NdFeB	1	21	90310C291558	Rear Bushing	PTFEC	1
9	90310C242015T	Pump casing Bushing	PTFEC	1					
10	90310C033025N	Rear casing Bushing	PTFEC	1					
11	90310C033045	Front Bushing	PTFEC	1					
12	55710T1160P	Impeller	PP	1					
13	92910E1667	O-Ring 228/BS628	EPDM	1					

- This drawing is for reference only

# EXPLODED VIEW

CODE: E 10418 Rev.:02

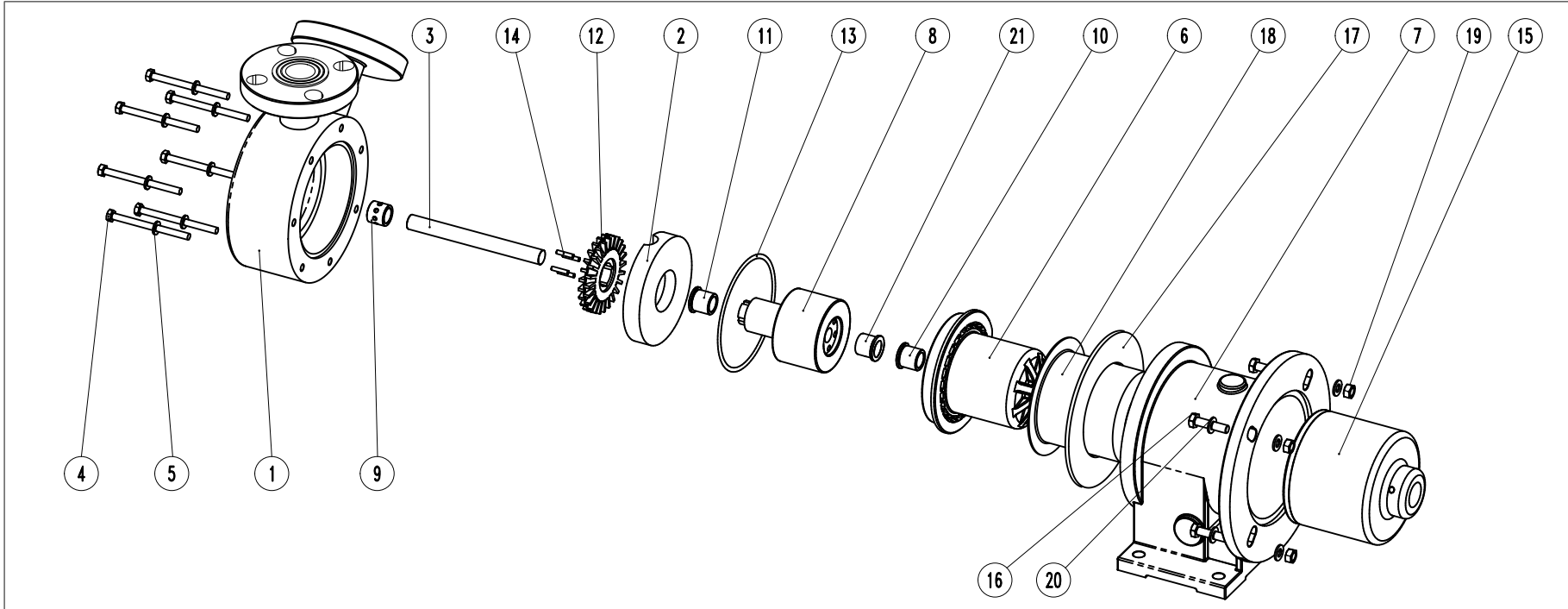

ITEM: Pump model: T MAG-P160 PVDF

# PART LIST

Motor: IEC Gr132 B5  
Port connection: Flanged

UNI EN1092-1 PN.10 / ANSI (ASA) B16.5 150#

ITEM N°	CODE META	Description	Material	Q.ty	ITEM N°	CODE META	Description	Material	Q.ty
1	56220T1160VU	Pump Casing	PVDF	1	14	56610D100028V	Impeller Pins	PVDF	4
2	55120T1160V	Volute Ring	PVDF	1	15	55810T112216NN	External magnet	A105/NdFeB	1
3	90010A03001T	Shaft	Al2o3	1	16	91610TE1045A2	Screw UNI24017 M10x45	A2-70	4
4	91610TE8100A2	Screw UNI24017 M8x100	A2-70	7	17	9015018751254A	Reinforced Ring	ANSI 304	1
5	91630N0816A2	Washer UNI6592 D.8x16	A2-70	7	18	93050T1122FC	Rear casing Armor	Carbon fiber	1
6	55610C1080V	Rear Casing	PVDF	1	19	91620N10A2	Nut UNI5588 M10	A2-70	4
7	56110C106516C	Bracket	WCB	1	20	91630N01020A2	Washer UNI6592 D.10x20	A2-70	8
8	55820T1122ANV	Internal Magnet	PVDF/NdFeB	1	21	90310C291558	Rear Bushing	PTFEC	1
9	90310C242015T	Pump casing Bushing	PTFEC	1					
10	90310C033025N	Rear casing Bushing	PTFEC	1					
11	90310C033045	Front Bushing	PTFEC	1					
12	55710T1160V	Impeller	PVDF	1					
13	92910V1667	O-Ring 228/BS628	Viton	1					

- This drawing is for reference only