

# OUTLINE DRAWING

CODE: D14371 Rev.:00

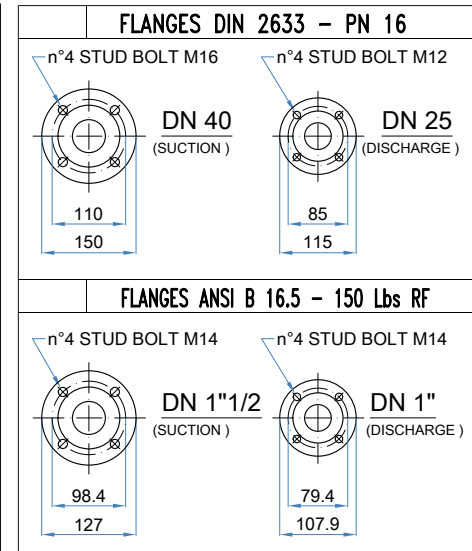
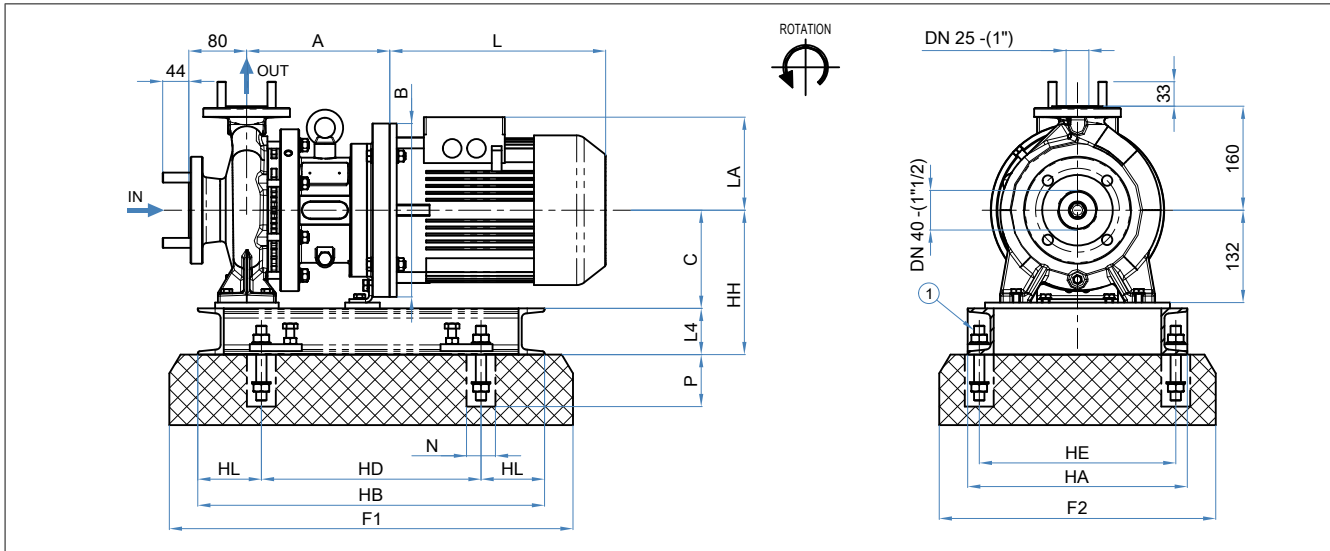

EXTERNAL MAGNET	PART. 1	FOOT PRINT SKETCH	PUMP						WEIGHT (kg)		
			MOTOR SIZE	A	B (Ø)	C	D	K		Weight pump (without motor)	Baseplate
			90	207	200	132	186	128.5	/	45	
			100/112	227	250	132	206	138.5	/		
			132	247	300	154	226	158.5	167.5		
			160	277	350	200	256	/	197.5		

MOTOR	MAX. (Kw)		SHAFT Ø d	DIMENSIONS			BASE PLATE N°	BASEPLATE (mm)								FOUNDATION (mm)				BOLTS Ød1 x l		
	2P	4P		L	LA	LB		HH	HB	HD	HL	HE	HA	L4	N° BOLTS	F1	F2	□ N	P			
90 S	1.5	1.1	24				H09	212														
90 L	2.2	1.5																				
100 L	3.0	2.2	28				H10	212	600	380	110	340	380	80	4	750	530	120	250	M16 x 270		
		3.0																				
112 M	4.0	4.0	28				H11	234														
132 S	5.5	5.5	38																			
	7.5																					
132 M	9.2	7.5	38																			

Motor:

Pump model: CN MAG-M 25-160/1 1/2x1x6

DATE:

ITEM:

PURCHASE ORDER:

CUSTOMER NAME:

# OUTLINE DRAWING

CODE: D14372 Rev.:00

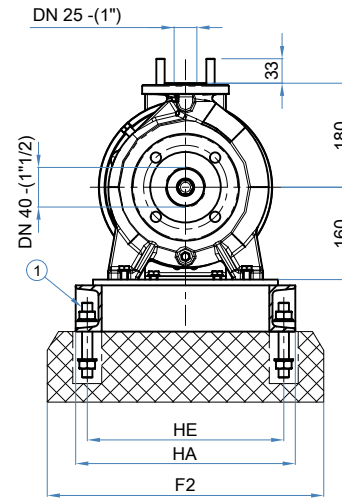
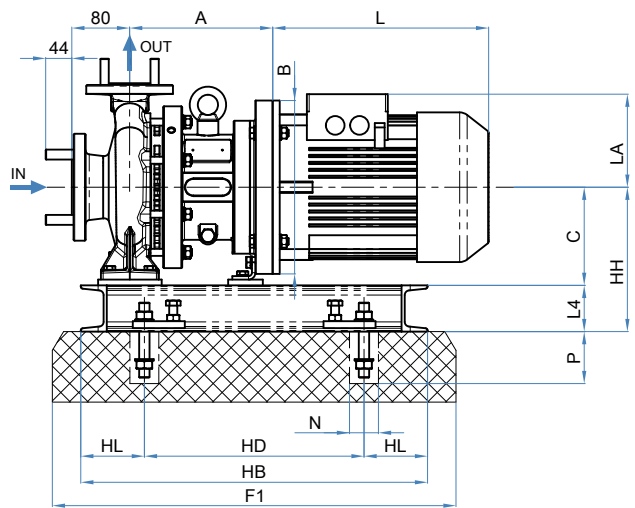

### FLANGES DIN 2633 - PN 16

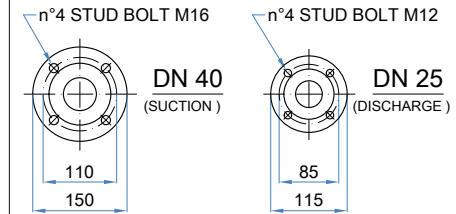

### FLANGES ANSI B 16.5 - 150 Lbs RF

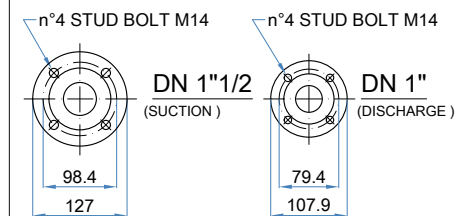

### EXTERNAL MAGNET

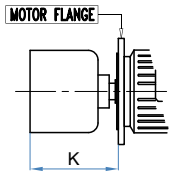

### PART. 1

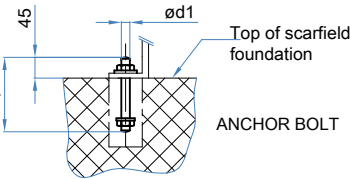

### FOOT PRINT SKETCH

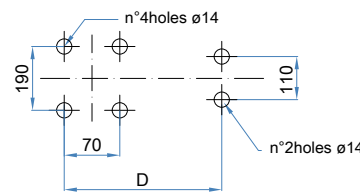

### PUMP

MOTOR SIZE	A	B (Ø)	C	D	K	
					A / B	C
90	228	200	160	186	128.5	/
100/112	228	250	160	206	138.5	/
132	248	300	160	228	158.5	167.5
160	278	350	200	258	/	197.5

### WEIGHT (kg)

Weight pump (without motor)	Baseplate
51	

MOTOR	MAX. (Kw)		SHAFT Ø d	DIMENSIONS			BASE PLATE N°	BASEPLATE (mm)								FOUNDATION (mm)				BOLTS Ød1 x l	
	2P	4P		L	LA	LB		HH	HB	HD	HL	HE	HA	L4	N° BOLTS	F1	F2	□ N	P		
90 S	1.5	1.1	24				H09	240													
90 L	2.2	1.5																			
100 L	3.0	2.2	28				H10	240													
		3.0																			
112 M	4.0	4.0	28				H22	240	600	380	110	340	380	80	4	750	530	120	250	M16 x 270	
132 S	5.5	5.5	38																		
	7.5																				
132 M	9.2	7.5	38																		

Motor:

Pump model: CN MAG-M 25-200 / 1/2x1x8

DATE:

ITEM:

PURCHASE ORDER:

CUSTOMER NAME:

# OUTLINE DRAWING

CODE: D10679 Rev.:01

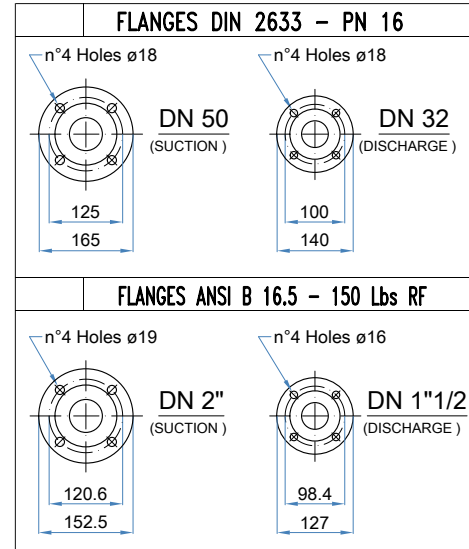
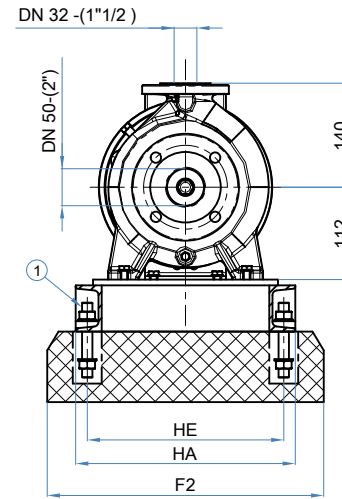
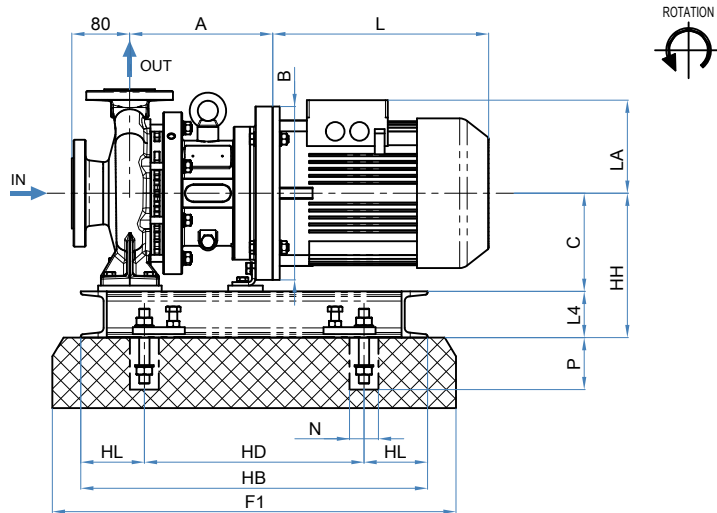

EXTERNAL MAGNET	PART. 1	FOOT PRINT SKETCH	PUMP							WEIGHT (kg)	
			MOTOR SIZE	A	B (Ø)	C	D	K		Weight pump (without motor)	Baseplate
			90	207	200	132	186	128.5	/	50	
			100/112	227	250	132	206	138.5	/		
			132	247	300	154	226	158.5	167.5		
			160	277	350	200	256	/	197.5		

MOTOR	MAX. (Kw)		SHAFT Ø d	DIMENSIONS				BASE PLATE N°	BASEPLATE (mm)								FOUNDATION (mm)				BOLTS Ød1 x l
	2P	4P		L	LA	LB	HH		HB	HD	HL	HE	HA	L4	N° BOLTS	F1	F2	□ N	P		
90 S	1.5	1.1	24				H01	212													
90 L	2.2	1.5																			
100 L	3.0	2.2 3.0	28				H02	212	600	380	110	340	380	80	4	750	530	120	250	M16 x 270	
112 M	4.0	4.0																			
132 S	5.5 7.5	5.5	38				H03	234													
132 M	9.2	7.5																			
160 M	11.0 15.0	/ /	42				H04	280													

Motor:

Pump model: CN MAG-M 32-125/2x1 1/2x5

DATE:

ITEM:

PURCHASE ORDER:

CUSTOMER NAME:



# OUTLINE DRAWING

CODE: D10681 Rev.:01

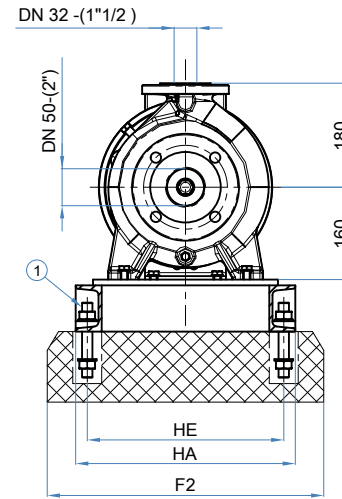
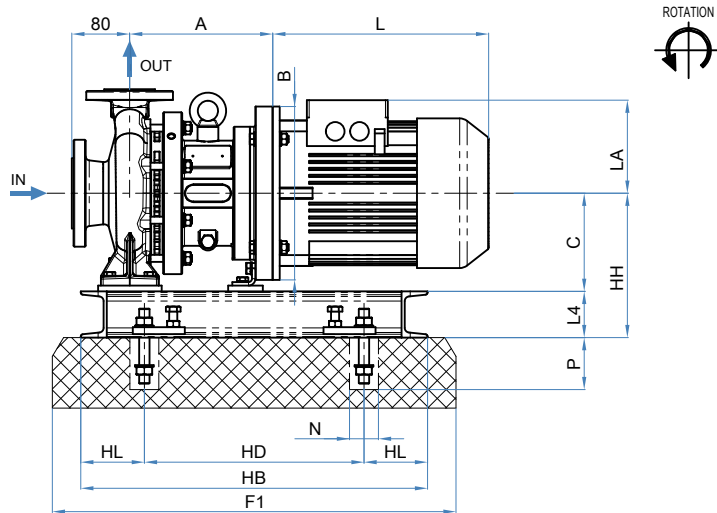

### FLANGES DIN 2633 - PN 16

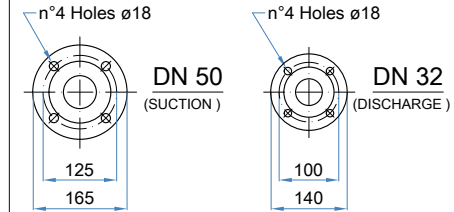

### FLANGES ANSI B 16.5 - 150 Lbs RF

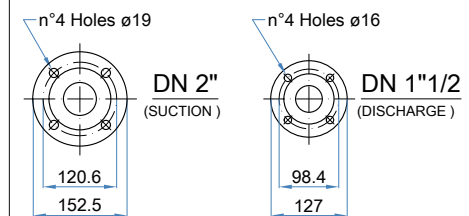

EXTERNAL MAGNET	PART. 1	FOOT PRINT SKETCH	PUMP						WEIGHT (kg)		
			MOTOR SIZE	A	B (Ø)	C	D	K		Weight pump (without motor)	Baseplate
			90	228	200	160	186	128.5	/	51	
			100/112	228	250	160	206	138.5	/		
			132	248	300	160	228	158.5	167.5		
			160	278	350	200	258	/	197.5		

MOTOR	MAX. (Kw)		SHAFT Ø d	DIMENSIONS				BASE PLATE N°	BASEPLATE (mm)								FOUNDATION (mm)				BOLTS Ød1 x l
	2P	4P		L	LA	LB	HH		HB	HD	HL	HE	HA	L4	N° BOLTS	F1	F2	□ N	P		
90 S	1.5	1.1	24				H09	240													
90 L	2.2	1.5																			
100 L	3.0	2.2	28				H10	240													
		3.0																			
112 M	4.0	4.0	28				H22	240	600	380	110	340	380	80	4	750	530	120	250	M16 x 270	
132 S	5.5	5.5	38																		
	7.5																				
132 M	9.2	7.5	38				H23	280													
160 M	11.0	/	42																		
	15.0	/																			

Motor:

Pump model: CN MAG-M 32-200/2x1 1/2x8

DATE:

ITEM:

PURCHASE ORDER:

CUSTOMER NAME:

# OUTLINE DRAWING

CODE: D10682 Rev.:01

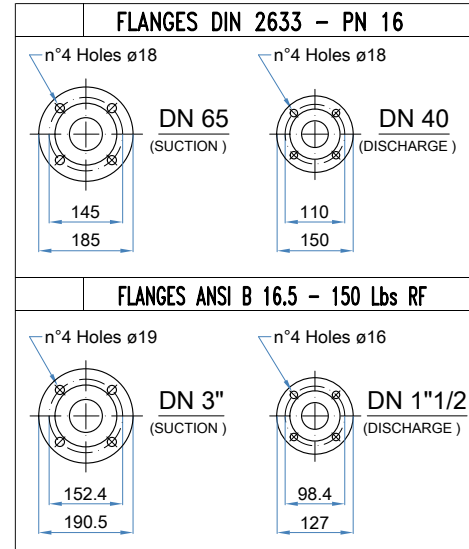
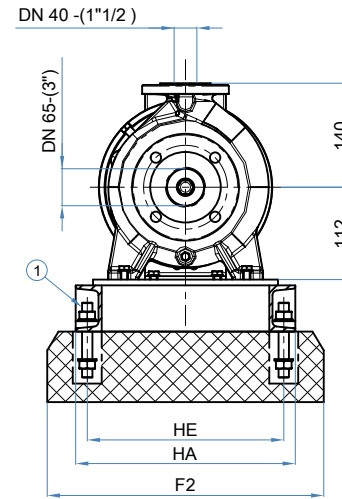
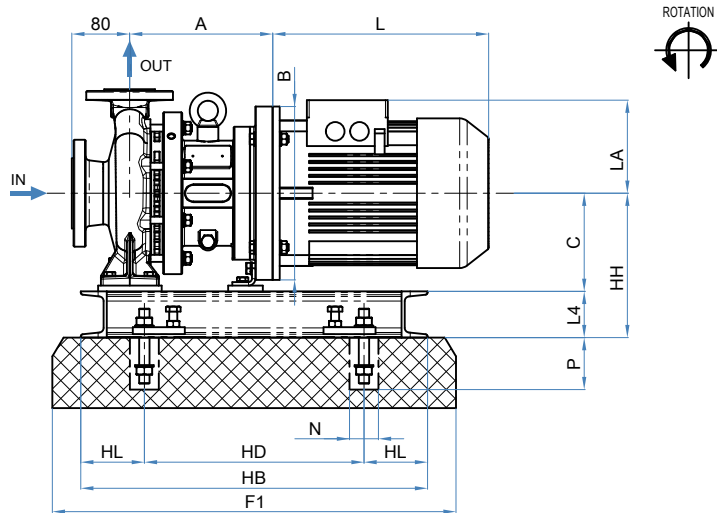

EXTERNAL MAGNET	PART. 1	FOOT PRINT SKETCH	PUMP							WEIGHT (kg)	
			MOTOR SIZE	A	B (Ø)	C	D	K		Weight pump (without motor)	Baseplate
			90	215	200	132	186	128.5	/	53	
			100/112	225	250	132	206	138.5	/		
			132	245	300	154	226	158.5	167.5		
			160	275	350	200	256	/	197.5		

MOTOR	MAX. (Kw)		SHAFT Ø d	DIMENSIONS			BASE PLATE N°	BASEPLATE (mm)							FOUNDATION (mm)				BOLTS Ød1 x l	
	2P	4P		L	LA	LB		HH	HB	HD	HL	HE	HA	L4	N° BOLTS	F1	F2	□ N		P
90 S	1.5	1.1	24				H05	212	600	380	110	340	380	80	4	750	530	120	250	M16 x 270
90 L	2.2	1.5																		
100 L	3.0	2.2	28				H06	212	600	380	110	340	380	80	4	750	530	120	250	M16 x 270
		3.0																		
112 M	4.0	4.0	28				H07	234	600	380	110	340	380	80	4	750	530	120	250	M16 x 270
132 S	5.5	5.5	38																	
	7.5																			
132 M	9.2	7.5	38				H08	280	600	380	110	340	380	80	4	750	530	120	250	M16 x 270
160 M	11.0	/	42																	
		15.0		/																

Motor:

Pump model: CN MAG-M 40-125/3x1 1/2x5

DATE:

ITEM:

PURCHASE ORDER:

CUSTOMER NAME:



# OUTLINE DRAWING

CODE: D10684 Rev.:01

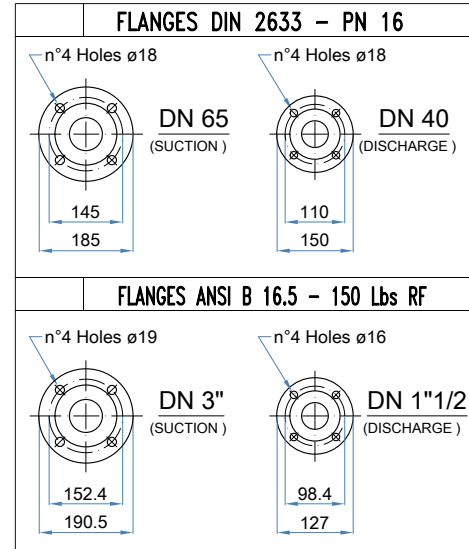
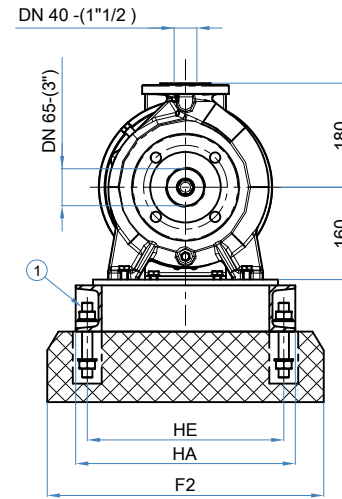
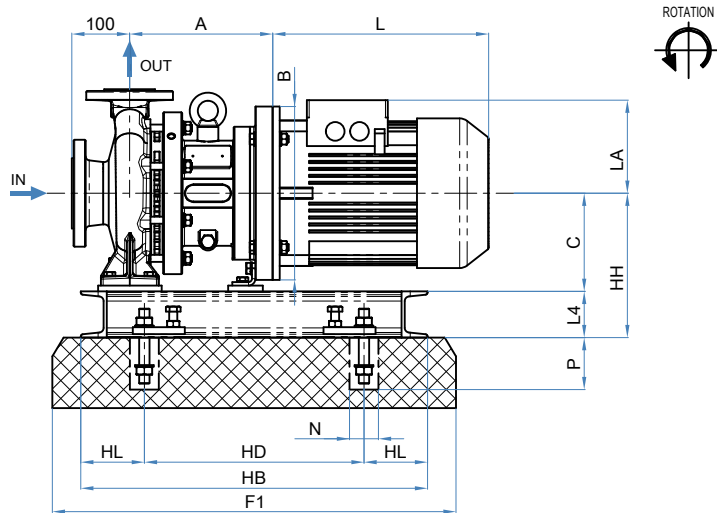

EXTERNAL MAGNET	PART. 1	FOOT PRINT SKETCH	PUMP							WEIGHT (kg)	
			MOTOR SIZE	A	B (Ø)	C	D	K		Weight pump (without motor)	Baseplate
			90	228	200	160	188	128.5	/	63	
			100/112	228	250	160	208	138.5	/		
			132	248	300	160	228	158.5	167.5		
			160	278	350	200	260	/	197.5		

MOTOR	MAX. (Kw)		SHAFT Ø d	DIMENSIONS			BASE PLATE N°	BASEPLATE (mm)							FOUNDATION (mm)				BOLTS Ød1 x l	
	2P	4P		L	LA	LB		HH	HB	HD	HL	HE	HA	L4	N° BOLTS	F1	F2	□ N		P
90 S	1.5	1.1	24				H17	240												
90 L	2.2	1.5																		
100 L	3.0	2.2	28				H18	240												
		3.0																		
112 M	4.0	4.0	28				H19	240	600	380	110	340	380	80	4	750	530	120	250	M16 x 270
132 S	5.5	5.5	38																	
	7.5																			
132 M	9.2	7.5	38				H21	280												
160 M	11.0	/	42																	
	15.0	/																		

Motor:

Pump model: CN MAG-M 40-200/3x1 1/2x8

DATE:

ITEM:

PURCHASE ORDER:

CUSTOMER NAME:



# OUTLINE DRAWING

CODE: D10685 Rev.:01

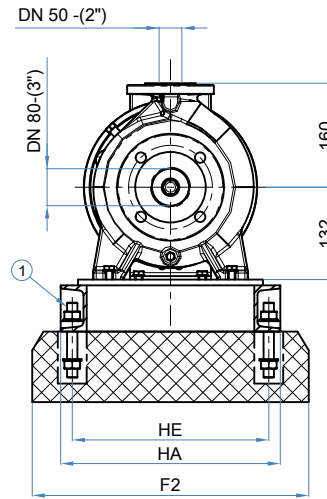
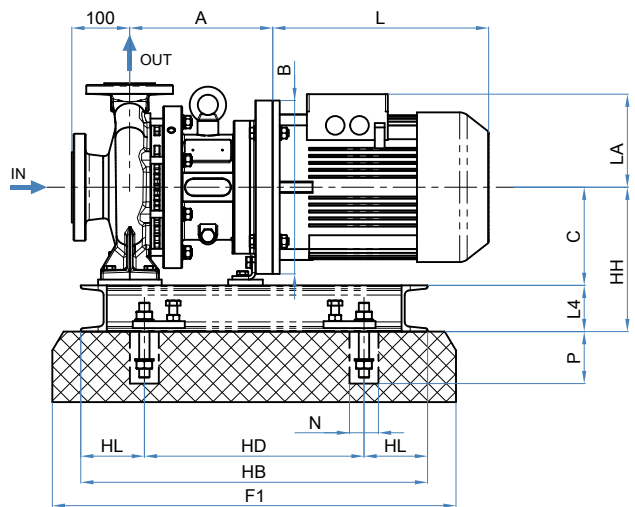

### FLANGES DIN 2633 - PN 16

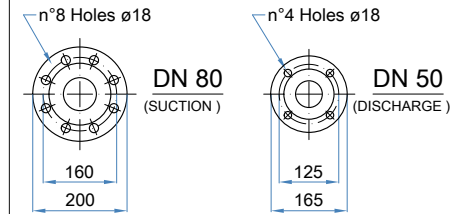

### FLANGES ANSI B 16.5 - 150 Lbs RF

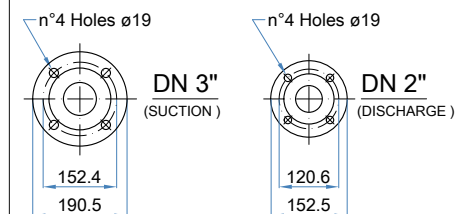

EXTERNAL MAGNET	PART. 1	FOOT PRINT SKETCH	PUMP							Weight pump (without motor)	Baseplate
			MOTOR SIZE	A	B (Ø)	C	D	K			
			90	207	200	152	186	128.5	/	56	
			100/112	227	250	152	206	138.5	/		
			132	247	300	154	226	158.5	167.5		
			160	277	350	200	256	/	197.5		

MOTOR	MAX. (Kw)		SHAFT Ø d	DIMENSIONS				BASE PLATE N°	BASEPLATE (mm)								FOUNDATION (mm)				BOLTS Ød1 x l
	2P	4P		L	LA	LB	HH		HB	HD	HL	HE	HA	L4	N° BOLTS	F1	F2	□ N	P		
90 S	1.5	1.1	24				H09	232	600	380	110	340	380	80	4	750	530	120	250	M16 x 270	
90 L	2.2	1.5																			
100 L	3.0	2.2	28				H10	232													
		3.0																			
112 M	4.0	4.0	28				H11	234													
132 S	5.5	5.5	38																		
	7.5																				
132 M	9.2	7.5	38				H12	280													
160 M	11.0	/	42																		
	15.0	/																			

Motor:

Pump model: CN MAG-M 50-125/3x2x5

DATE:

ITEM:

PURCHASE ORDER:

CUSTOMER NAME:

# OUTLINE DRAWING

CODE: D10686 Rev.:01

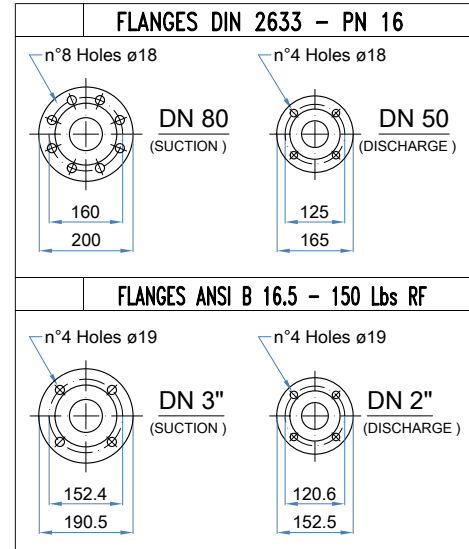
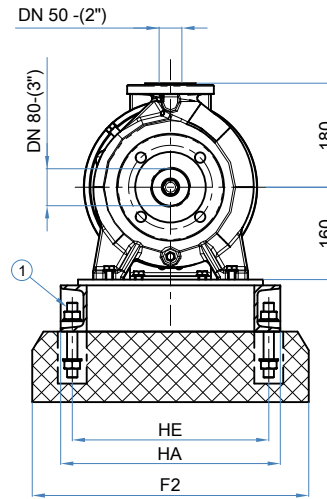
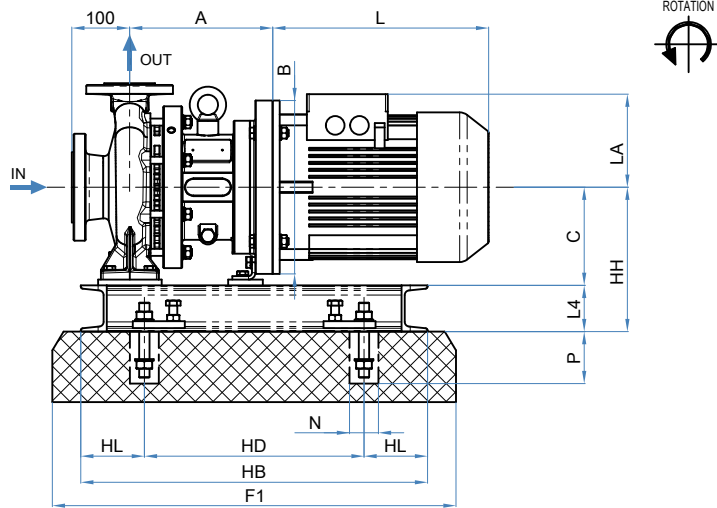

EXTERNAL MAGNET	PART. 1	FOOT PRINT SKETCH	PUMP						WEIGHT (kg)		
			MOTOR SIZE	A	B (Ø)	C	D	K		Weight pump (without motor)	Baseplate
			90	227	200	160	188	128.5	/	65	
			100/112	247	250	160	208	138.5	/		
			132	267	300	160	228	158.5	167.5		
			160	297	350	200	260	/	197.5		

MOTOR	MAX. (Kw)		SHAFT Ø d	DIMENSIONS				BASE PLATE N°	BASEPLATE (mm)								FOUNDATION (mm)				BOLTS Ød1 x l		
	2P	4P		L	LA	LB	HH		HB	HD	HL	HE	HA	L4	N° BOLTS	F1	F2	□ N	P				
90 S	1.5	1.1	24				H17	240															
90 L	2.2	1.5																					
100 L	3.0	2.2	28				H18	240															
		3.0																					
112 M	4.0	4.0	28				H19	240	600	380	110	340	380	80	4	750	530	120	250				
132 S	5.5	5.5	38																				
	7.5																						
132 M	9.2	7.5	38				H21	280															
160 M	11.0	/	42																				
	15.0	/																					

Motor:

Pump model: CN MAG-M 50-160/3x2x6

DATE:

ITEM:

PURCHASE ORDER:

CUSTOMER NAME:

# OUTLINE DRAWING

CODE: D10687 Rev.:01



Pump model: CN MAG-M 50-200/3x2x8

Motor:

DATE:

ITEM:

PURCHASE ORDER:

CUSTOMER NAME:

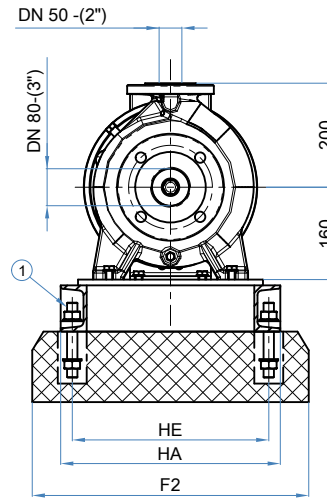
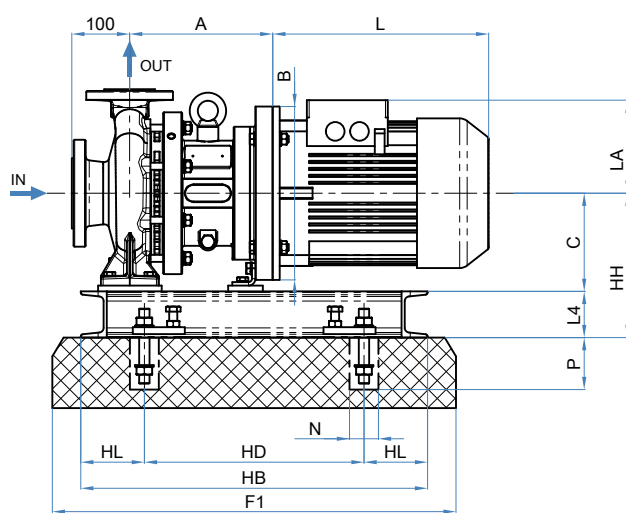

### FLANGES DIN 2633 - PN 16

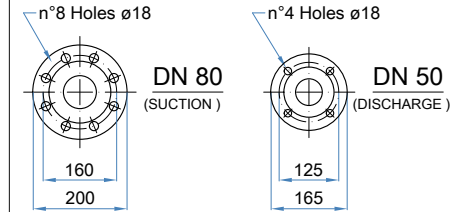

### FLANGES ANSI B 16.5 - 150 Lbs RF

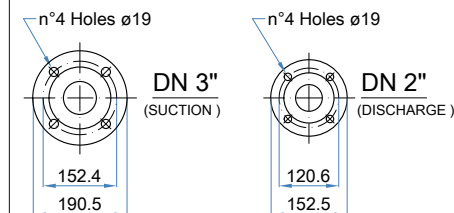

EXTERNAL MAGNET	PART. 1	FOOT PRINT SKETCH	PUMP							WEIGHT (kg)	
			MOTOR SIZE	A	B (Ø)	C	D	K		Weight pump (without motor)	Baseplate
			90	228	200	160	188	128.5	/	70	
			100/112	228	250	160	208	138.5	/		
			132	248	300	160	228	158.5	167.5		
			160/180	278	350	200	260	/	197.5		

MOTOR	MAX. (Kw)		SHAFT Ø d	DIMENSIONS			BASE PLATE N°	BASEPLATE (mm)								FOUNDATION (mm)				BOLTS Ød1 x l
	2P	4P		L	LA	LB		HH	HB	HD	HL	HE	HA	L4	N° BOLTS	F1	F2	□ N	P	
90 S	1.5	1.1	24				H17	240	600	380	110	340	380	80	4	750	530	120	250	M16 x 270
90 L	2.2	1.5																		
100 L	3.0	2.2	28				H18	240	600	380	110	340	380	80	4	750	530	120	250	M16 x 270
		3.0																		
112 M	4.0	4.0	28				H19	240	600	380	110	340	380	80	4	750	530	120	250	M16 x 270
132 S	5.5	5.5	38																	
	7.5																			
132 M	9.2	7.5	38				H21	280	600	380	110	340	380	80	4	750	530	120	250	M16 x 270
160 M	11.0	/	42																	
	15.0	/																		
180 M	18.5	/	48																	
	22.0	/																		



# OUTLINE DRAWING

CODE: D10689 Rev.:01

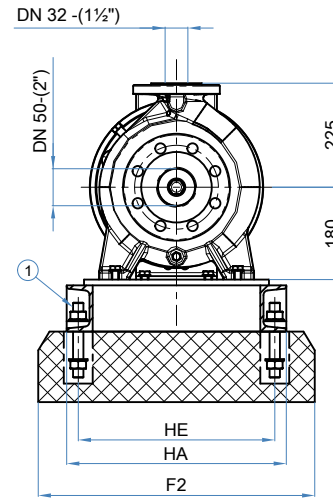
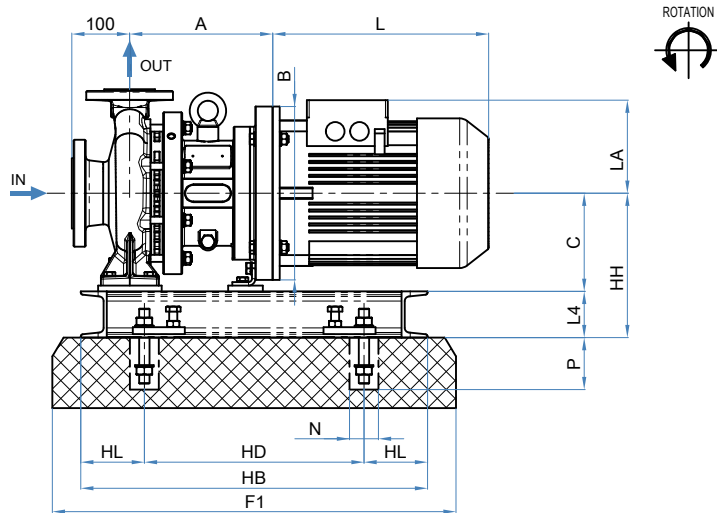

### FLANGES DIN 2633 - PN 16

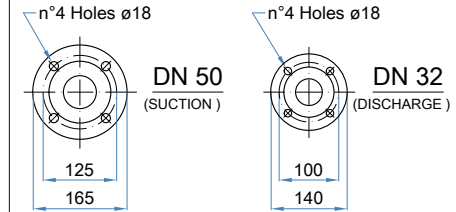

### FLANGES ANSI B 16.5 - 150 Lbs RF

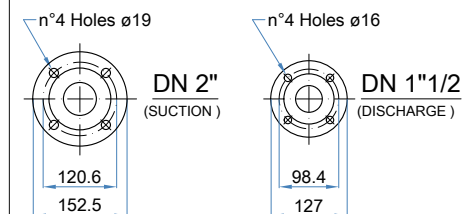

EXTERNAL MAGNET	PART. 1	FOOT PRINT SKETCH	PUMP							WEIGHT (kg)	
			MOTOR SIZE	A	B (Ø)	C	D	K		Weight pump (without motor)	Baseplate
			132	305	300	180	285	184.5	/	110	
			160/180	335	350	190	310	214.5	/		
			200	335	400	210	310	214.5	231.5		

MOTOR	MAX. (Kw)		SHAFT Ø d	DIMENSIONS			BASE PLATE N°	BASEPLATE (mm)							FOUNDATION (mm)				BOLTS Ød1 x l			
	2P	4P		L	LA	LB		HH	HB	HD	HL	HE	HA	L4	N° BOLTS	F1	F2	□ N		P		
132 S	5.5	5.5	38				H30	270														
	7.5																					
132 M	9.2	7.5	38																			
	9.2																					
160 M	11.0	11.0	42				H31	270	750	530	110	500	540	80	4	900	700	120	250	M16 x 270		
	15.0																					
160 L	18.5	15.0	42																			
180 M	22.0	18.5	48				H31	270														
180 L	/	22.0	48				H31	270														
200 L	/	30.0	55				H31	290														

Motor:

Pump model: CN MAG-M 32-250/2x1-1/2x10

DATE:

ITEM:

PURCHASE ORDER:

CUSTOMER NAME:

# OUTLINE DRAWING

CODE: D10690 Rev.:01

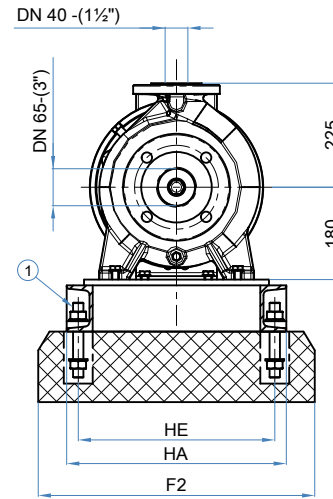
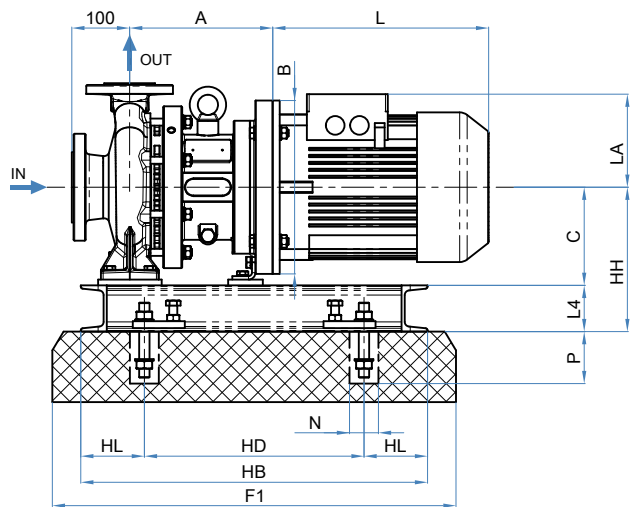

### FLANGES DIN 2633 - PN 16

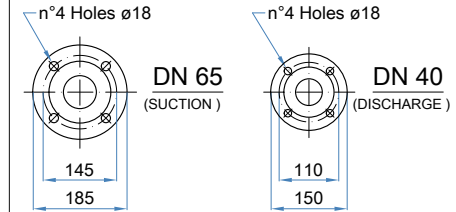

### FLANGES ANSI B 16.5 - 150 Lbs RF

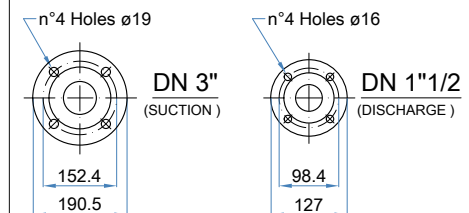

EXTERNAL MAGNET	PART. 1	FOOT PRINT SKETCH	PUMP							WEIGHT (kg)	
			MOTOR SIZE	A	B (Ø)	C	D	K		Weight pump (without motor)	Baseplate
			132	305	300	180	285	184.5	/	115	
			160/180	335	350	190	310	214.5	/		
			200	335	400	210	310	214.5	231.5		

MOTOR	MAX. (Kw)		SHAFT Ø d	DIMENSIONS			BASE PLATE N°	BASEPLATE (mm)								FOUNDATION (mm)				BOLTS Ød1 x l	
	2P	4P		L	LA	LB		HH	HB	HD	HL	HE	HA	L4	N° BOLTs	F1	F2	□ N	P		
132 S	5.5	5.5	38				H30	260													
	7.5																				
132 M	9.2	7.5	38																		
		9.2																			
160 M	11.0	11.0	42				H33	260	750	530	110	500	540	80	4	900	700	120	250	M16 x 270	
	15.0																				
160 L	18.5	15.0	42																		
180 M	22.0	18.5	48				H33	260													
180 L	/	22.0	48																		
200 L	/	30.0	55				H33	290													

Motor:

Pump model: CN MAG-M 40-250/3x1-1/2x10

DATE:

ITEM:

PURCHASE ORDER:

CUSTOMER NAME:

# OUTLINE DRAWING

CODE: D10691 Rev.:01

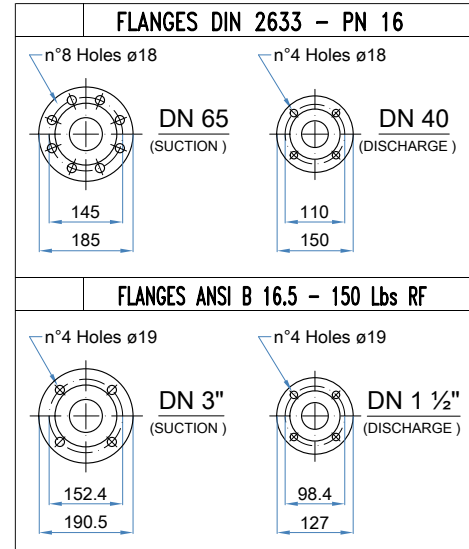
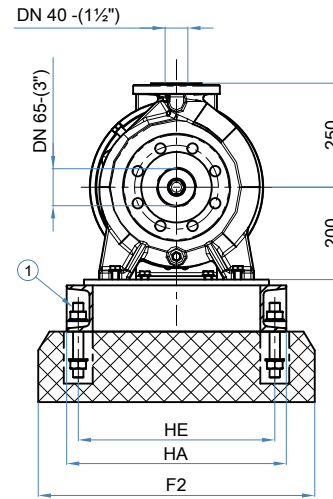
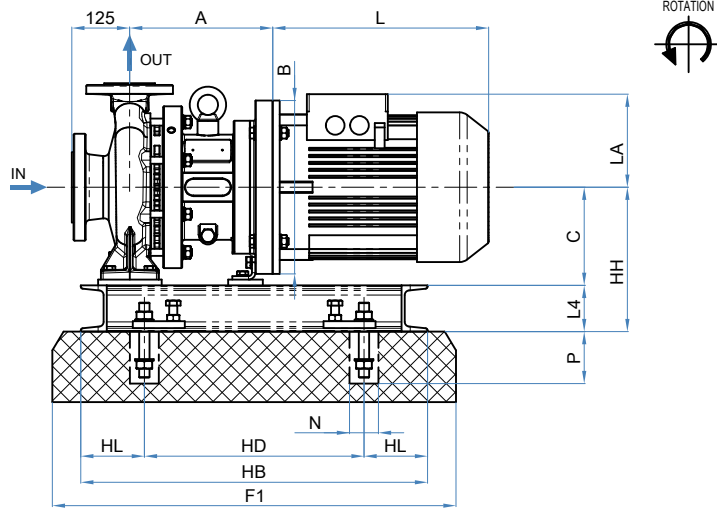

EXTERNAL MAGNET	PART. 1	FOOT PRINT SKETCH	PUMP							WEIGHT (kg)	
			MOTOR SIZE	A	B (Ø)	C	D	K		Weight pump (without motor)	Baseplate
			160/180	335	350	200	310	214.5	/	145	
			200	335	400	210	310	214.5	231.5		

MOTOR	MAX. (Kw)		SHAFT Ø d	DIMENSIONS			BASE PLATE N°	BASEPLATE (mm)							FOUNDATION (mm)				BOLTS Ød1 x l		
	2P	4P		L	LA	LB		HH	HB	HD	HL	HE	HA	L4	N° BOLTS	F1	F2	□ N		P	
160 M	11.0	11.0	42				H40	280													
	15.0																				
160 L	18.5	15.0	42				H40	280	750	530	110	500	540	80	4	900	700	120	250	M16 x 270	
180 M	22.0	18.5	48				H40	280													
180 L	-	22.0	48				H41	290													
200 L	-	30.0	55																		

Motor:

Pump model: CN MAG-M 40-315/3x1 1/2x13

DATE:

ITEM:

PURCHASE ORDER:

CUSTOMER NAME:

# OUTLINE DRAWING

CODE: D10692 Rev.:01

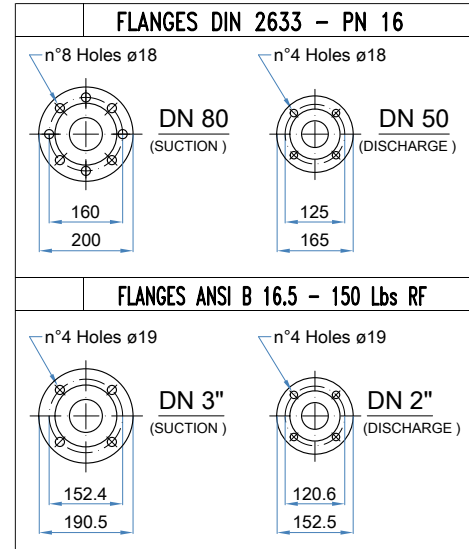
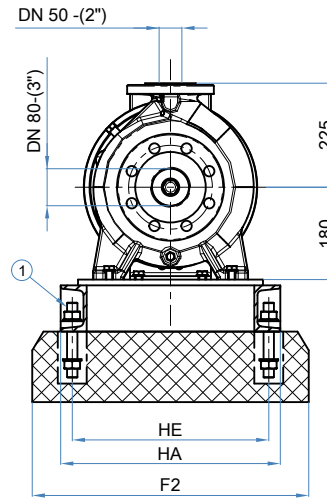
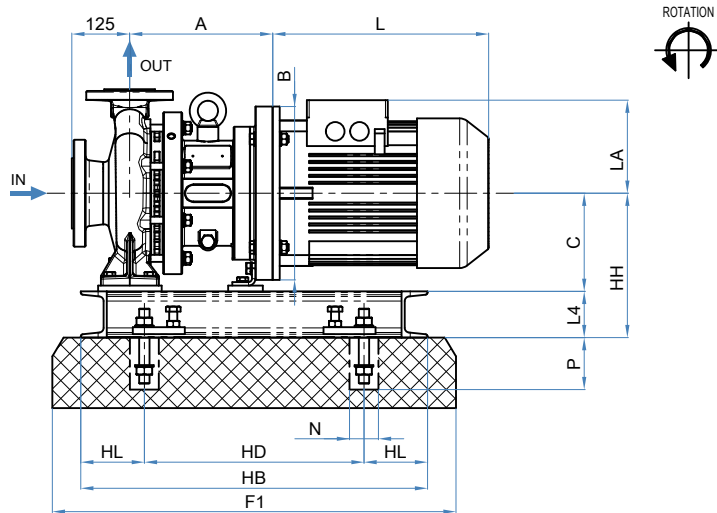

EXTERNAL MAGNET	PART. 1	FOOT PRINT SKETCH	PUMP							WEIGHT (kg)	
			MOTOR SIZE	A	B (Ø)	C	D	K		Weight pump (without motor)	Baseplate
			132	305	300	180	285	184.5	/	120	
			160/180	335	350	190	310	214.5	/		
			200	335	400	210	310	214.5	231.5		

MOTOR	MAX. (Kw)		SHAFT Ø d	DIMENSIONS			BASE PLATE N°	BASEPLATE (mm)							FOUNDATION (mm)				BOLTS Ød1 x l	
	2P	4P		L	LA	LB		HH	HB	HD	HL	HE	HA	L4	N° BOLTS	F1	F2	□ N		P
132 S	5.5	5.5	38				H30	270												
	7.5																			
132 M	9.2	7.5	38																	
		9.2																		
160 M	11.0	11.0	42				H33	270	750	530	110	500	540	80	4	900	700	120	250	M16 x 270
	15.0																			
160 L	18.5	15.0	42																	
180 M	22.0	18.5	48				H33	270												
180 L	-	22.0	48																	
200 L	-	30.0	55				H32	290												

Motor:

Pump model: CN MAG-M 50-250/3/2x10

DATE:

ITEM:

PURCHASE ORDER:

CUSTOMER NAME:



# OUTLINE DRAWING

CODE: D10693 Rev.:01

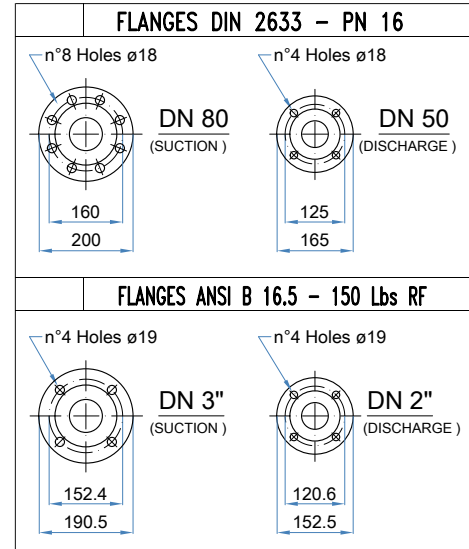
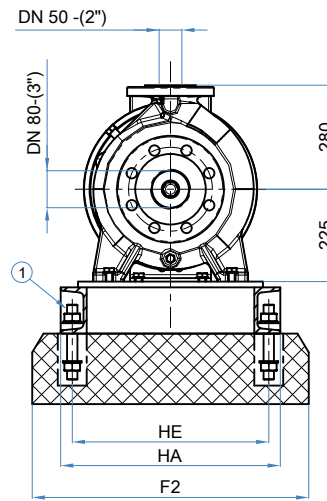
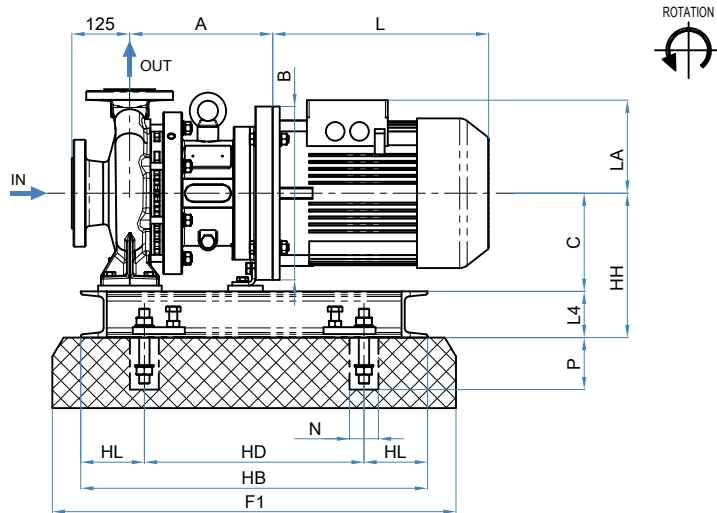

EXTERNAL MAGNET	PART. 1	FOOT PRINT SKETCH	PUMP							WEIGHT (kg)	
			MOTOR SIZE	A	B (Ø)	C	D	K		Weight pump (without motor)	Baseplate
			160/180	335	300	225	310	214.5	/	145	
			200	335	400	225	310	214.5	231.5		

MOTOR	MAX. (Kw)		SHAFT Ø d	DIMENSIONS				BASE PLATE N°	BASEPLATE (mm)							FOUNDATION (mm)				BOLTS Ød1 x l
	2P	4P		L	LA	LB	HH		HB	HD	HL	HE	HA	L4	N° BOLTS	F1	F2	□ N	P	
160 M	11.0	11.0	42				H40	305												
	15.0																			
160 L	18.5	15.0	42				H40	305	750	530	110	500	540	80	4	900	700	120	250	M16 x 270
180 M	22.0	18.5	48																	
180 L	-	22.0	48				H40	305												
200 L	-	30.0	55																	

Motor: \_\_\_\_\_  
 Pump model: CN MAG-M 50-315/3/2x13

DATE: \_\_\_\_\_  
 ITEM: \_\_\_\_\_  
 PURCHASE ORDER: \_\_\_\_\_  
 CUSTOMER NAME: \_\_\_\_\_

# OUTLINE DRAWING

CODE: D10694 Rev.:01

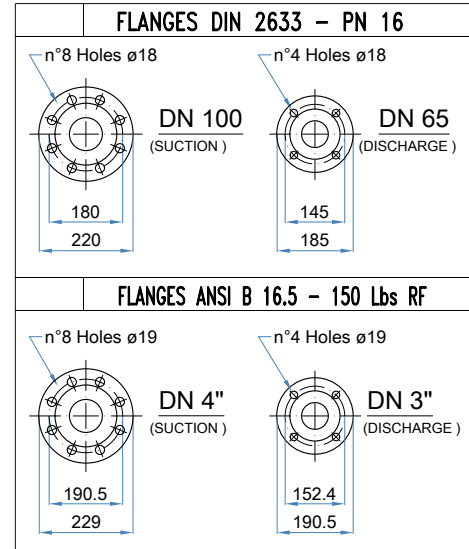
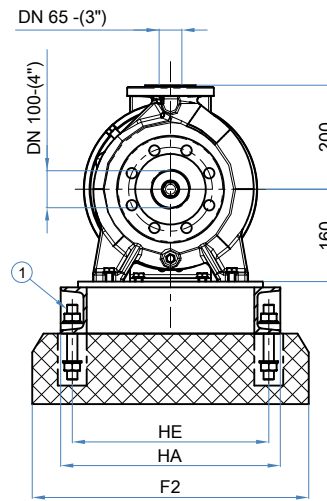
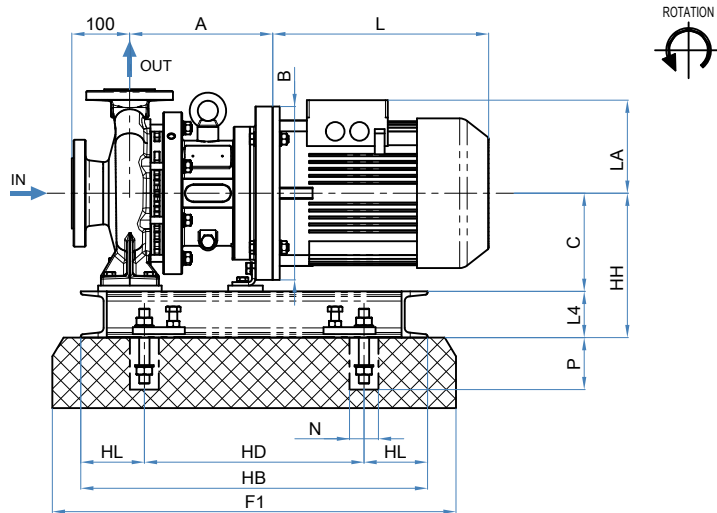

EXTERNAL MAGNET	PART. 1	FOOT PRINT SKETCH	PUMP							WEIGHT (kg)	
			MOTOR SIZE	A	B (Ø)	C	D	K		Weight pump (without motor)	Baseplate
			132	305	300	180	285	184.5	/	100	
			160/180	335	350	180	315	214.5	/		
			200	335	400	210	310	214.5	231.5		

MOTOR	MAX. (Kw)		SHAFT Ø d	DIMENSIONS			BASE PLATE N°	BASEPLATE (mm)							FOUNDATION (mm)				BOLTS Ød1 x l	
	2P	4P		L	LA	LB		HH	HB	HD	HL	HE	HA	L4	N° BOLTS	F1	F2	□ N		P
132 S	5.5	5.5	38				H37	260												
	7.5																			
132 M	9.2	7.5	38																	
		9.2																		
160 M	11.0	11.0	42				H38	260	750	530	110	500	540	80	4	900	700	120	250	M16 x 270
	15.0																			
160 L	18.5	15.0	42																	
180 M	22.0	18.5	48				H38	260												
180 L	/	22.0	48																	
200 L	/	30.0	55				H39	290												

Motor:

Pump model: CN MAG-M 65-160/4x3x6

DATE:

ITEM:

PURCHASE ORDER:

CUSTOMER NAME:



# OUTLINE DRAWING

CODE: D10696 Rev.:01



Pump model: CN MAG-M 65-250/43x10

Motor:

DATE:

ITEM:

PURCHASE ORDER:

CUSTOMER NAME:

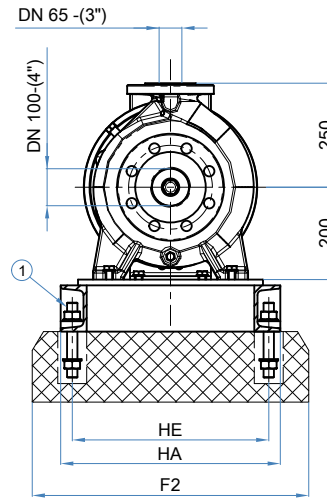
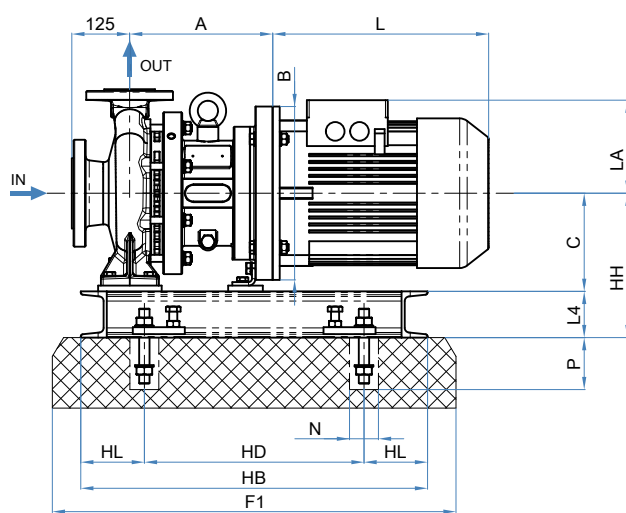

### FLANGES DIN 2633 - PN 16

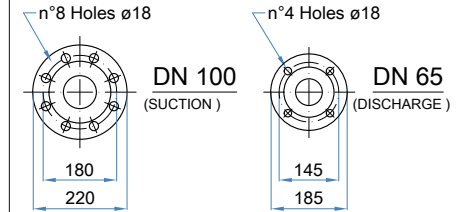

### FLANGES ANSI B 16.5 - 150 Lbs RF

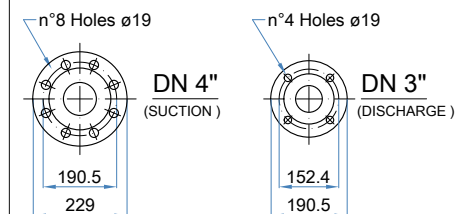

EXTERNAL MAGNET	PART. 1	FOOT PRINT SKETCH	PUMP							WEIGHT (kg)	
			MOTOR SIZE	A	B (Ø)	C	D	K		Weight pump (without motor)	Baseplate
			132	305	300	200	297	184.5	/	125	
			160/180	335	350	200	322	214.5	/		
			200	335	400	210	322	214.5	231.5		

MOTOR	MAX. (Kw)		SHAFT Ø d	DIMENSIONS			BASE PLATE N°	BASEPLATE (mm)							FOUNDATION (mm)				BOLTS Ød1 x l	
	2P	4P		L	LA	LB		HH	HB	HD	HL	HE	HA	L4	N° BOLTS	F1	F2	□ N		P
132 S	5.5	5.5	38				H34	280												
	7.5																			
132 M	9.2	7.5 9.2	38																	
160 M	11.0 15.0	11.0	42				H35	280	750	530	110	500	540	80	4	900	700	120	250	M16 x 270
160 L	18.5	15.0	42																	
180 M	22.0	18.5	48				H35	280												
180 L	22.0	22.0	48																	
200 L	30.0	30.0	55				H36	290												
	37.0	/																		



# OUTLINE DRAWING

CODE: D10698 Rev.:01

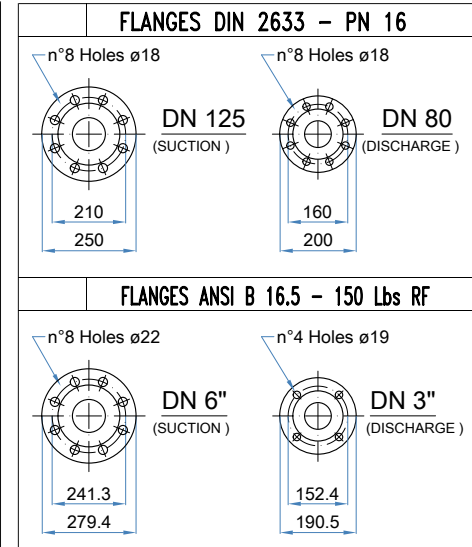
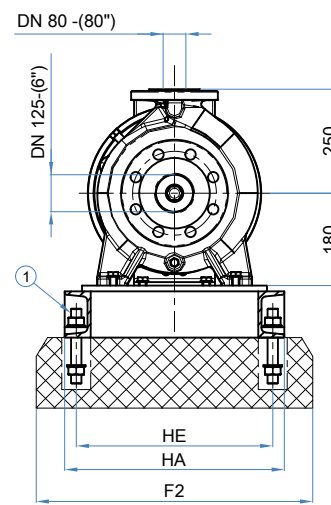
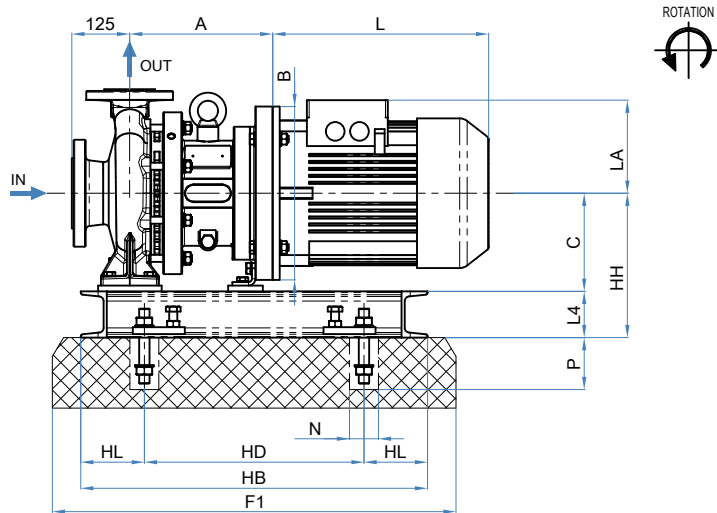

EXTERNAL MAGNET	PART. 1	FOOT PRINT SKETCH	PUMP							WEIGHT (kg)	
			MOTOR SIZE	A	B (Ø)	C	D	K		Weight pump (without motor)	Baseplate
			132	305	300	180	297	184.5	/	110	
			160/180	335	350	180	327	214.5	/		
			200	335	400	210	322	214.5	231.5		

MOTOR	MAX. (Kw)		SHAFT Ø d	DIMENSIONS			BASE PLATE N°	BASEPLATE (mm)							FOUNDATION (mm)				BOLTS Ød1 x l	
	2P	4P		L	LA	LB		HH	HB	HD	HL	HE	HA	L4	N° BOLTS	F1	F2	□ N		P
132 S	5.5	5.5	38				H43	260												
	7.5																			
132 M	9.2	7.5	38																	
		9.2																		
160 M	11.0	11.0	42				H44	260	750	530	110	500	540	80	4	900	700	120	250	M16 x 270
	15.0																			
160 L	18.5	15.0	42																	
180 M	22.0	18.5	48				H44	260												
180 L	/	22.0	48																	
200 L	/	30.0	55				H45	290												

Motor:

Pump model: CN MAG-M 80-200/6x3,8

DATE:

ITEM:

PURCHASE ORDER:

CUSTOMER NAME:

# OUTLINE DRAWING

CODE: D10699 Rev.:01

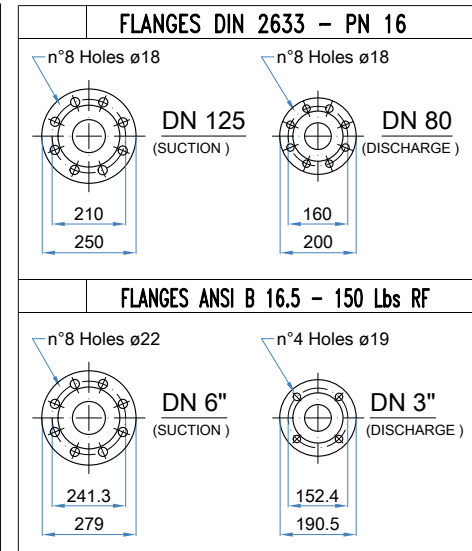
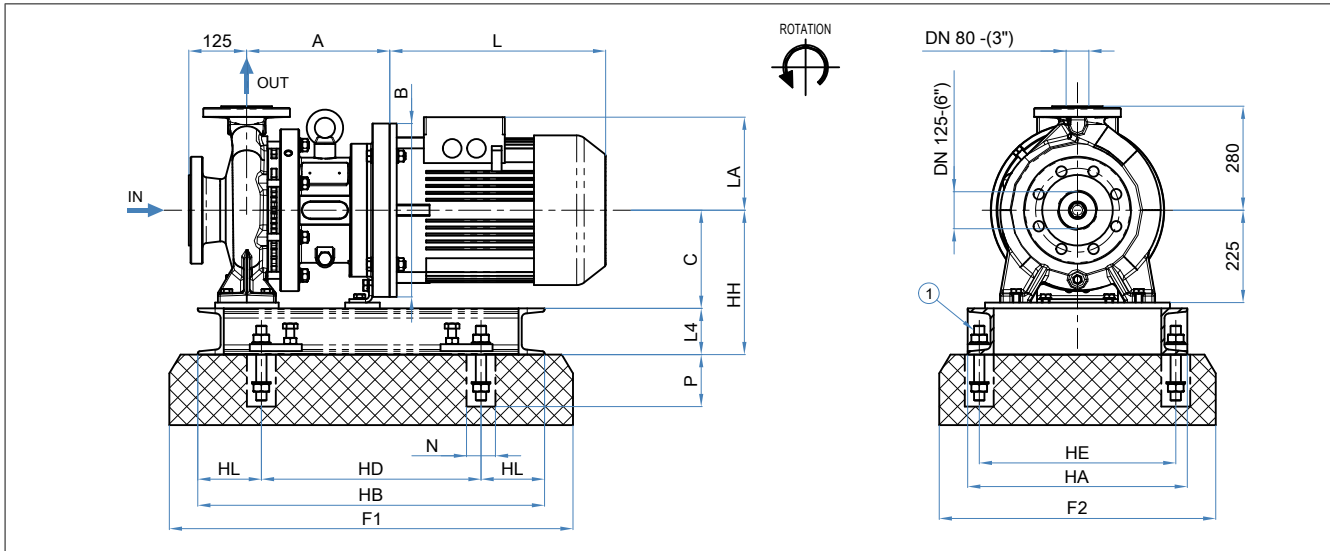

EXTERNAL MAGNET	PART. 1	FOOT PRINT SKETCH	PUMP							WEIGHT (kg)	
			MOTOR SIZE	A	B (Ø)	C	D	K		Weight pump (without motor)	Baseplate
			132	305	300	225	297	184.5	/	145	
			160/180	335	350	225	322	214.5	/		
			200	335	400	225	322	214.5	231.5		

MOTOR	MAX. (Kw)		SHAFT Ø d	DIMENSIONS				BASE PLATE N°	BASEPLATE (mm)								FOUNDATION (mm)				BOLTS Ød1 x l
	2P	4P		L	LA	LB	HH		HB	HD	HL	HE	HA	L4	N° BOLTS	F1	F2	□ N	P		
132 S	5.5	5.5	38				H46	305													
	7.5																				
132 M	9.2	7.5	38																		
		9.2																			
160 M	11.0	11.0	42				H47	305	750	530	110	500	540	80	4	900	700	120	250	M16 x 270	
	15.0																				
160 L	18.5	15.0	42																		
180 M	22.0	18.5	48																		
180 L	/	22.0	48																		
200 L	/	30.0	55																		

Motor: \_\_\_\_\_  
 Pump model: CN MAG-M 80-250/6.3x10

DATE: \_\_\_\_\_  
 ITEM: \_\_\_\_\_  
 PURCHASE ORDER: \_\_\_\_\_  
 CUSTOMER NAME: \_\_\_\_\_

# OUTLINE DRAWING

CODE: D10700 Rev.:01

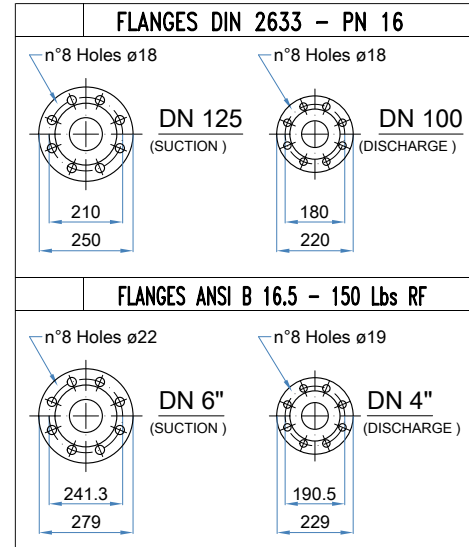
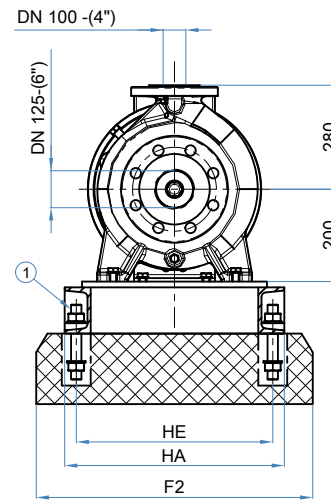
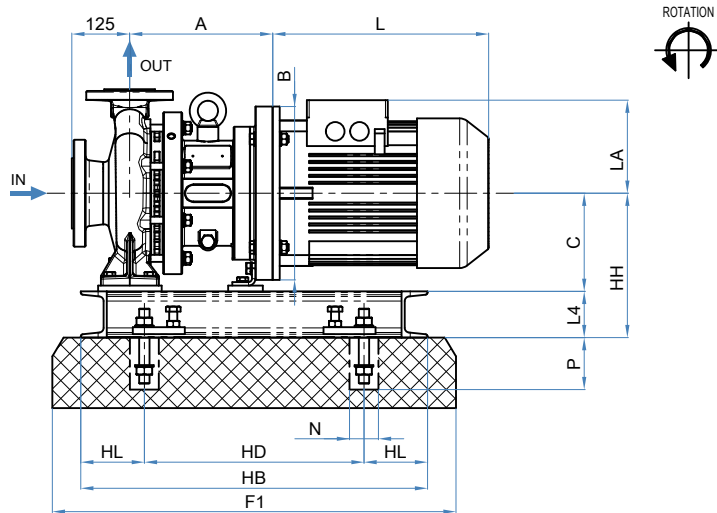

EXTERNAL MAGNET	PART. 1	FOOT PRINT SKETCH	PUMP							WEIGHT (kg)	
			MOTOR SIZE	A	B (Ø)	C	D	K		Weight pump (without motor)	Baseplate
			132	305	300	200	297	184.5	/	135	
			160/180	355	350	200	327	214.5	/		
			200	355	400	210	322	214.5	231.5		

MOTOR	MAX. (Kw)		SHAFT Ø d	DIMENSIONS			BASE PLATE N°	BASEPLATE (mm)							FOUNDATION (mm)				BOLTS Ød1 x l	
	2P	4P		L	LA	LB		HH	HB	HD	HL	HE	HA	L4	N° BOLTS	F1	F2	□ N		P
132 S	5.5	5.5	38				H34	280												
	7.5																			
132 M	9.2	7.5	38																	
		9.2																		
160 M	11.0	11.0	42				H42	280	750	530	110	500	540	80	4	900	700	120	250	M16 x 270
	15.0																			
160 L	18.5	15.0	42																	
180 M	22.0	18.5	48				H42	280												
180 L	/	22.0	48																	
200 L	/	30.0	55				H36	290												

Motor:

Pump model: CN MAG-M 100-200/6x4x8

DATE:

ITEM:

PURCHASE ORDER:

CUSTOMER NAME: