

# EXPLODED VIEW

CODE: E10169 Rev.:01

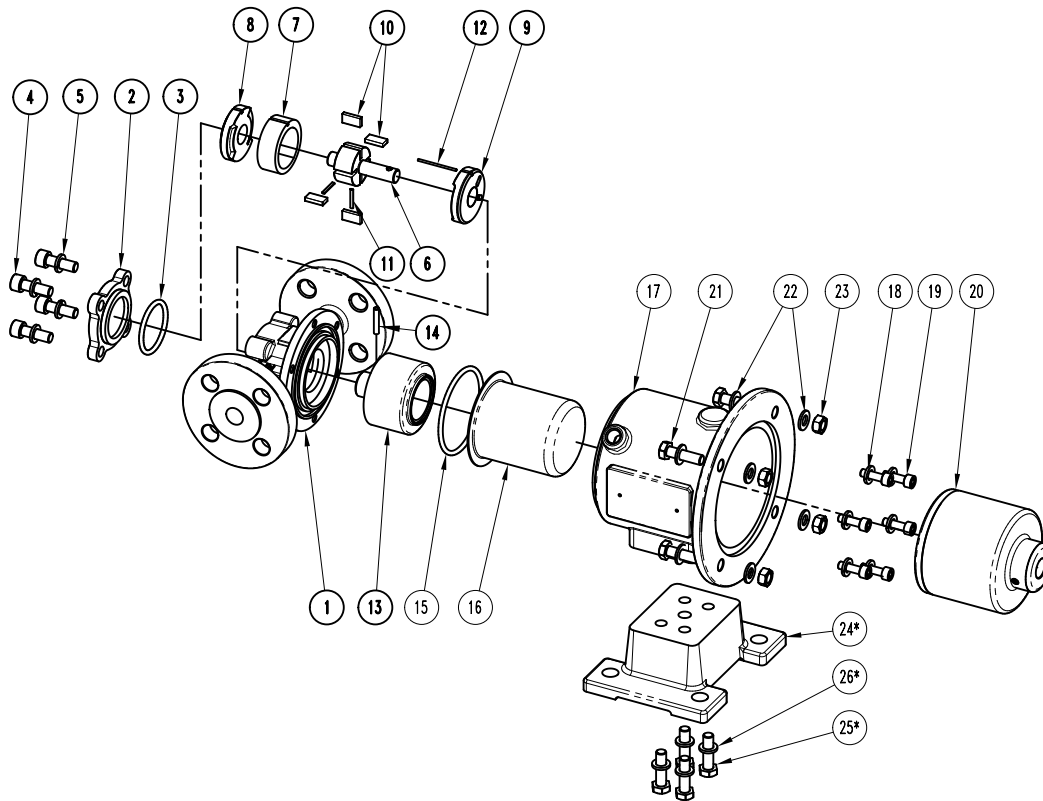

\*: Only for B5 motor version

## PART LIST

ITEM N°	CODE	Description	Material	Q.ty
1	56210VBLAD	Pump casing DIN PN.25	CF8M	1
	56210VBLAA	Pump casing ANSI 150#		
	56210VBLAB	Pump casing ANSI 300#		
2	55520VBLA	Pump casing cover	CF8M	1
3	92910V5039	O-Ring 4200/BS226	Viton	1
4	91610TCE11025A2	Screw UNI5931 M10x25	A2-70	4
5	91630S01017A2	Washer UNI1751 D.10x17	A2-70	4
6	501600VBA	Rotor	AISI 316	1
	92410FVB05	Stator VB 500 L/h		
	92410FVB06	Stator VB 600 L/h		
	92410FVB07	Stator VB 700 L/h		
	92410FVB08	Stator VB 800 L/h		
	92410FVB09	Stator VB 900 L/h		
	92410FVB10	Stator VB 1000 L/h		
8	91110FVBA	Front disc	Graphite	1
9	91110FVBP	Rear disc	Graphite	1
10	92010FVB	Vane	Graphite	4
11	916500500A2	Pins L500/600/700	AISI 316	2
	916500800A2	Pins L800		
	916500900A2	Pins L900		
	916501080A2	Pins L1080		
12	91650VBA2N	Guide pins	AISI 316	1
13	55820VBNA	Internal magnet	AISI316/NdFeB	1
14	51650VAA	Lock pins	AISI 316	1
15	92910V6627	O-Ring 4262/BS231	Viton	1
16	9080A11007	Rear casing	AISI 316	1
17	56110VAVB06C	Bracket	WCB	1
18	91630S0611A2	Washer UNI1751 D.6x11	A2-70	6
19	91610TCE1620A2	Screw UNI5931 M6x20	A2-70	6
20	55810VB06N	External magnet	A105/NdFeB	1
21	91610TE835A2	Screw UNI24017 M8x35	A2-70	4
22	91630N0816A2	Washer UNI6592 D.8x16	A2-70	8
23	91620N08A2	Nut UNI 5588 M8	A2-70	4
24*	95910VAC	Foot	WCB	1
25*	91610TE814A2	Screw UNI24017 M8x14	A2-70	4
26*	91630S0814A2	Washer UNI1751 D.8x14	A2-70	4

Pump model: VB IN LINE  
ITEM:  
Std version

Motor: IEC Gr 71  
Port connection: Flanged

- This drawing is for reference only

# EXPLODED VIEW

CODE: E10170 Rev.:01

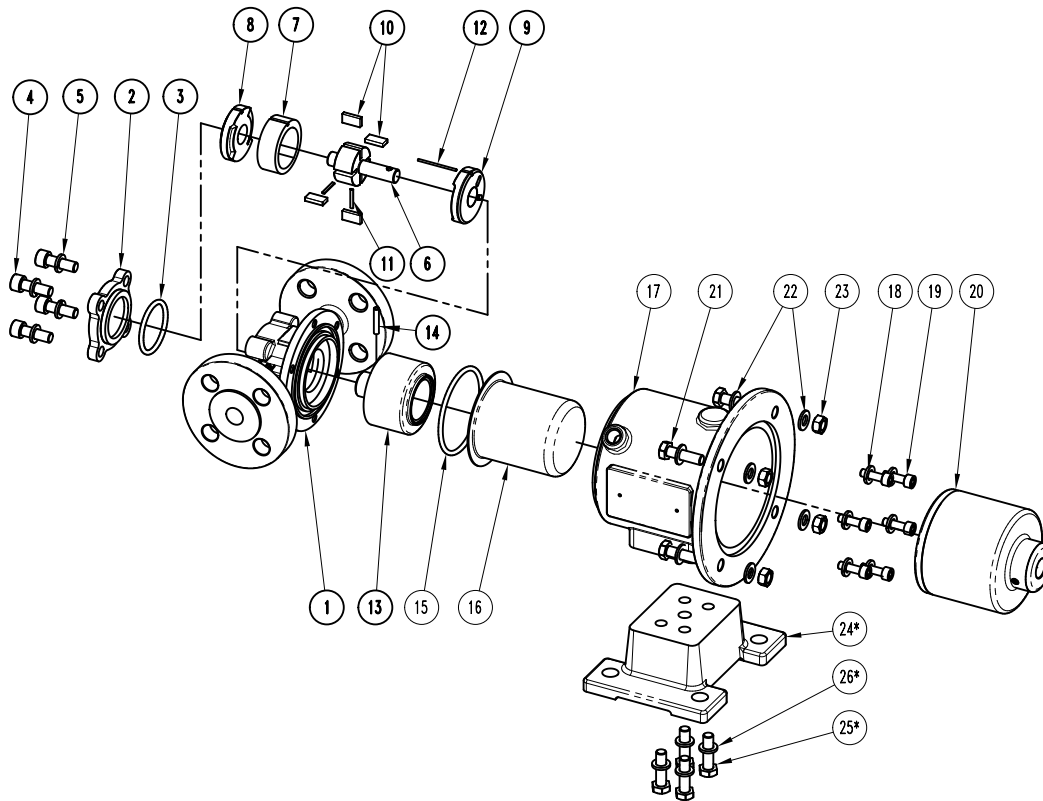

\*: Only for B5 motor version

## PART LIST

ITEM N°	CODE	Description	Material	Q.ty
1	56210VBLAD	Pump casing DIN PN.25	CF8M	1
	56210VBLAA	Pump casing ANSI 150#		
	56210VBLAB	Pump casing ANSI 300#		
2	55520VBLA	Pump casing cover	CF8M	1
3	92910V5039	O-Ring 4200/BS226	Viton	1
4	91610TCE11025A2	Screw UNI5931 M10x25	A2-70	4
5	91630S01017A2	Washer UNI1751 D.10x17	A2-70	4
6	501600VBA	Rotor	AISI 316	1
	92410FVB05	Stator VB 500 L/h		
	92410FVB06	Stator VB 600 L/h		
	92410FVB07	Stator VB 700 L/h		
	92410FVB08	Stator VB 800 L/h		
	92410FVB09	Stator VB 900 L/h		
	92410FVB10	Stator VB 1000 L/h		
8	91110FVBA	Front disc	Graphite	1
9	91110FVBP	Rear disc	Graphite	1
10	92010FVB	Vane	Graphite	4
11	916500500A2	Pins L500/600/700	AISI 316	2
	916500800A2	Pins L800		
	916500900A2	Pins L900		
	916501080A2	Pins L1080		
12	91650VBA2N	Guide pins	AISI 316	1
13	55820VBNA	Internal magnet	AISI316/NdFeB	1
14	51650VAA	Lock pins	AISI 316	1
15	92910V6627	O-Ring 4262/BS231	Viton	1
16	9080A11007	Rear casing	AISI 316	1
17	56110VAVB08C	Bracket	WCB	1
18	91630S0611A2	Washer UNI1751 D.6x11	A2-70	6
19	91610TCE1620A2	Screw UNI5931 M6x20	A2-70	6
20	55810VB08N	External magnet	A105/NdFeB	1
21	91610TE835A2	Screw UNI24017 M8x35	A2-70	4
22	91630N0816A2	Washer UNI6592 D.8x16	A2-70	8
23	91620N08A2	Nut UNI 5588 M8	A2-70	4
24	95910VAC	Foot	WCB	1
25*	91610TE814A2	Screw UNI24017 M8x14	A2-70	4
26*	91630S0814A2	Washer UNI1751 D.8x14	A2-70	4

Pump model: VB IN LINE  
ITEM: Std version

Motor: IEC Gr 80  
Port connection: Flanged

- This drawing is for reference only

# EXPLODED VIEW

CODE: E10227 Rev.:01

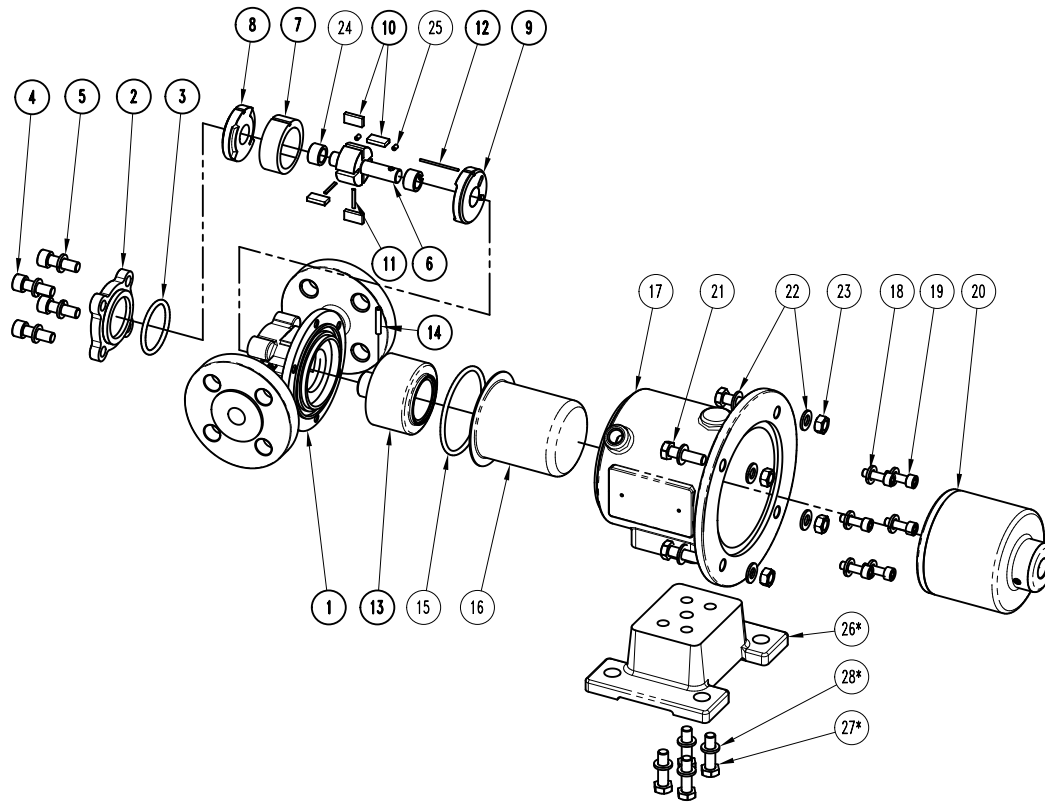

\*: Only for B5 motor version

## PART LIST

ITEM N°	CODE	Description	Material	Q.ty
1	56210VBLAD	Pump casing DIN PN.25	CF8M	1
	56210VBLAA	Pump casing ANSI 150#		
	56210VBLAB	Pump casing ANIS 300#		
2	55520VBLA	Pump casing cover	CF8M	1
3	92910V5039	O-Ring 4200/BS226	Viton	1
4	91610TCE11025A2	Screw UNI5931 M10x25	A2-70	4
5	91630S01017A2	Washer UNI1751 D.10x17	A2-70	4
6	501600VBSA	Rotor	AISI 316	1
	52410RVB05	Stator VB 500 L/h	Metcar 312	1
	52410RVB06	Stator VB 600 L/h		
	52410RVB07	Stator VB 700 L/h		
	52410RVB08	Stator VB 800 L/h		
	52410RVB09	Stator VB 900 L/h		
	52410RVB10	Stator VB 1000 L/h		
8	91110RVBAS	Front disc	Metcar 312	1
9	91110RVBPS	Rear disc	Metcar 312	1
10	92010RVB	Vane	Metcar 312	4
11	916500500A2	Pins L500/600/700	AISI 316	2
	916500800A2	Pins L800		
	916500900A2	Pins L900		
	916501080A2	Pins L1080		
12	91650VBA2N	Guide pins	AISI 316	1
13	55820VBNA	Internal magnet	AISI316/NdFeB	1
14	51650VAA	Lock pins	AISI 316	1
15	92910V6627	O-Ring 4262/BS231	Viton	1
16	9080A11007	Rear casing	AISI 316	1
17	56110VAVB06C	Bracket	WCB	1
18	91630S0611A2	Washer UNI1751 D.6x11	A2-70	6
19	91610TCE1620A2	Screw UNI5931 M6x20	A2-70	6
20	55810VB06N	External magnet	A105/NdFeB	1
21	91610TE835A2	Screw UNI24017 M8x35	A2-70	4
22	91630N0816A2	Washer UNI6592 D.8x16	A2-70	8
23	91620N08A2	Nut UNI 5588 M8	A2-70	4
24	90230S022013	Sleeve rotor	SiC	2
25	916700308A4	Socket screw UNI5927 M3x8	A4-70	2
26*	95910VAC	Foot	WCB	1
27*	91610TE814A2	Screw UNI24017 M8x14	A2-70	4
28*	91630S0814A2	Washer UNI1751 D.8x14	A2-70	4

Pump model: VB IN LINE  
ITEM:  
1 SiC version

Motor: IEC Gr 71  
Port connection: Flanged

- This drawing is for reference only

# EXPLODED VIEW

CODE: E10228 Rev.:01

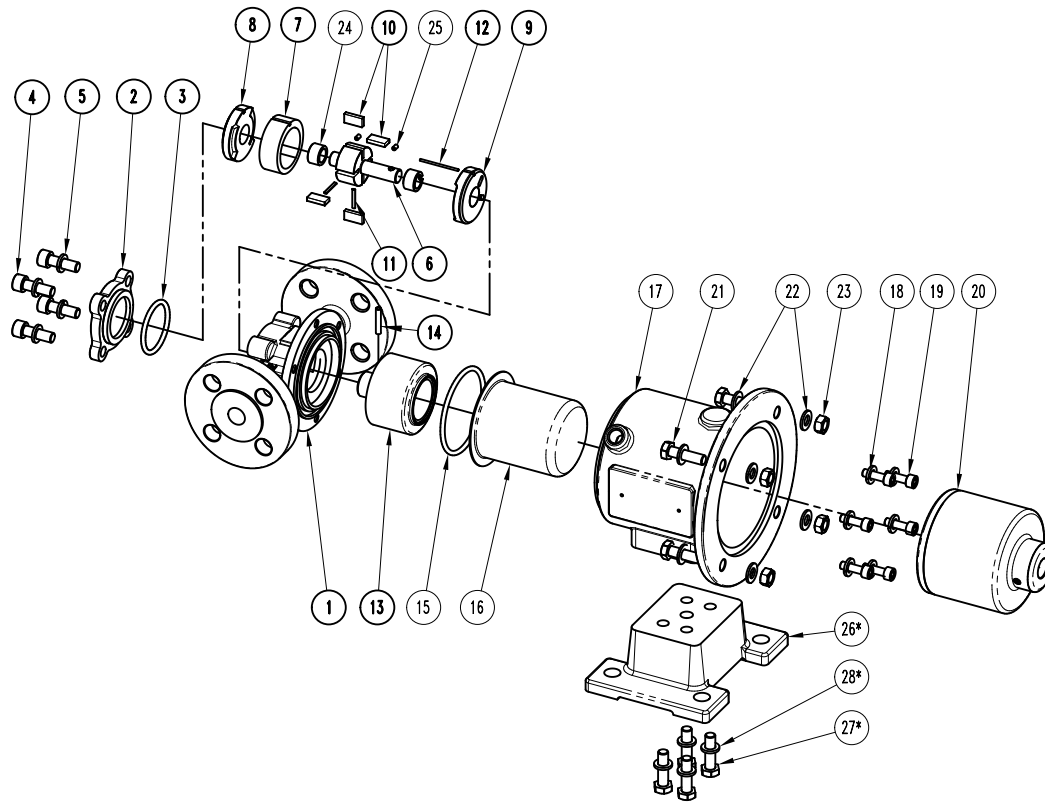

\*: Only for B5 motor version

## PART LIST

ITEM N°	CODE	Description	Material	Q.ty
1	56210VBLAD	Pump casing DIN PN.25	CF8M	1
	56210VBLAA	Pump casing ANSI 150#		
	56210VBLAB	Pump casing ANSI 300#		
2	55520VBLA	Pump casing cover	CF8M	1
3	92910V5039	O-Ring 4200/BS226	Viton	1
4	91610TCE11025A2	Screw UNI5931 M10x25	A2-70	4
5	91630S01017A2	Washer UNI1751 D.10x17	A2-70	4
6	501600VBSA	Rotor	AISI 316	1
	52410RVB05	Stator VB 500 L/h	Metcar 312	1
	52410RVB06	Stator VB 600 L/h		
	52410RVB07	Stator VB 700 L/h		
	52410RVB08	Stator VB 800 L/h		
	52410RVB09	Stator VB 900 L/h		
	52410RVB10	Stator VB 1000 L/h		
8	91110RVBAS	Front disc	Metcar 312	1
9	91110RVBPS	Rear disc	Metcar 312	1
10	92010RVB	Vane	Metcar 312	4
11	916500500A2	Pins L500/600/700	AISI 316	2
	916500800A2	Pins L800		
	916500900A2	Pins L900		
	916501080A2	Pins L1080		
12	91650VBA2N	Guide pins	AISI 316	1
13	55820VBNA	Internal magnet	AISI316/NdFeB	1
14	51650VAA	Lock pins	AISI 316	1
15	92910V6627	O-Ring 4262/BS231	Viton	1
16	9080A11007	Rear casing	AISI 316	1
17	56110VAVB08C	Bracket	WCB	1
18	91630S0611A2	Washer UNI1751 D.6x11	A2-70	6
19	91610TCE1620A2	Screw UNI5931 M6x20	A2-70	6
20	55810VB08N	External magnet	A105/NdFeB	1
21	91610TE835A2	Screw UNI24017 M8x35	A2-70	4
22	91630N0816A2	Washer UNI6592 D.8x16	A2-70	8
23	91620N08A2	Nut UNI 5588 M8	A2-70	4
24	90230S022013	Sleeve rotor	SiC	2
25	916700308A4	Socket screw UNI5927 M3x8	A4-70	2
26*	95910VAC	Foot	WCB	1
27*	91610TE814A2	Screw UNI24017 M8x14	A2-70	4
28*	91630S0814A2	Washer UNI1751 D.8x14	A2-70	4

Pump model: VB IN LINE  
ITEM:  
1 SiC version

Motor: IEC Gr 80  
Port connection: Flanged

- This drawing is for reference only