

EXPLODED VIEW

CODE: E 10444 Rev.:01

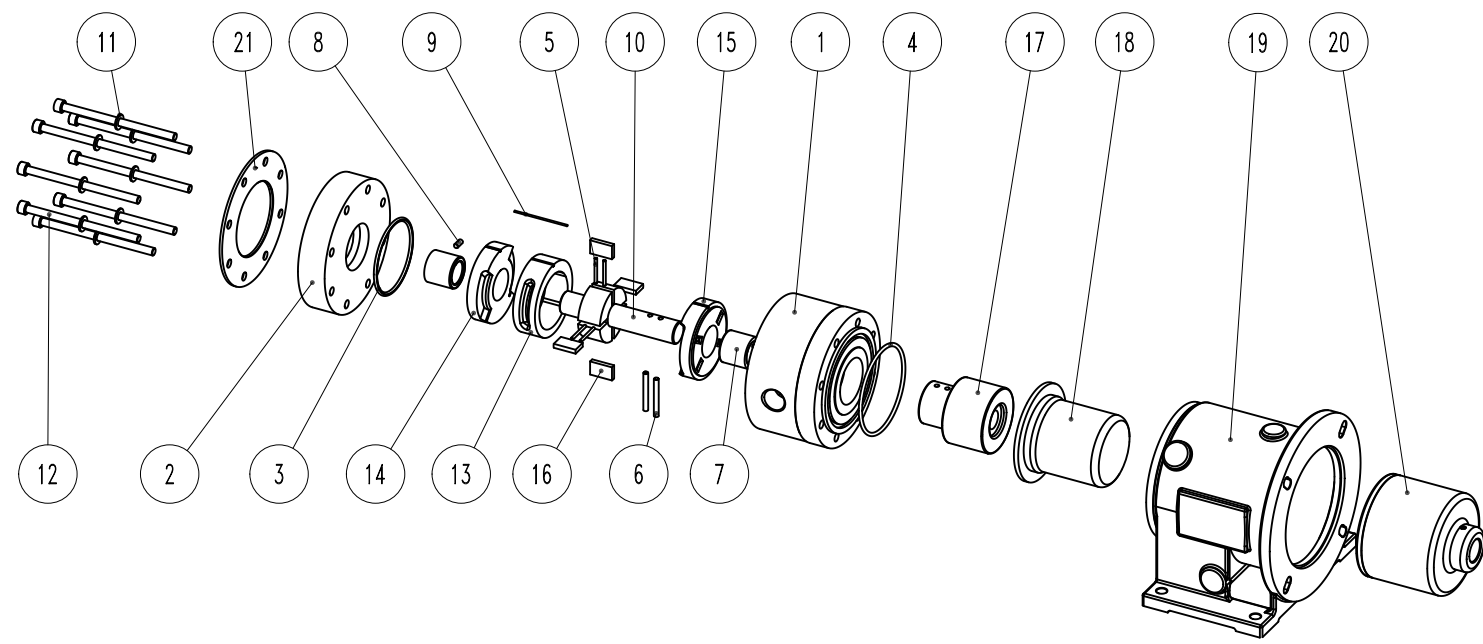

ITEM: Pump model: VPM PP

PART LIST

Motor: IEC 90 B3/B5
 Port connection: Threaded
 BSP-F UNI ISO 228/1 | NPT-F USAS B2-1/1968

ITEM N°	META CODE	Description	Material	Q.ty	ITEM N°	META CODE	Description	Material	Q.ty
1	56220VPMGP	Pump Casing BSP	PP	1	12	91610TCEI8130A2	Screw UNI5931 M8x130	A2-70	8
	56220VPMPN	Pump Casing NPT			13	92410FVB10	Stator VB 1000 L/h	Graphite	1
2	55520VPM	Pump casing cover	PP	1	92410FVM15	Stator VM 1500 L/h	Graphite		
3	92910E7580	O-Ring 4300/BS234	EPDM	1	92410FVM20	Stator VM 2000 L/h		Graphite	1
4	92910E9167	O-Ring 4362/BS239	EPDM	1	14	91110FVPMAS	Front Disc		
5	91650V1000	Pins L1000	PVDF	4	15	91110FVPMPS	Rear Disc	Graphite	1
	91650V1500	Pins L1500			16	92010FVM	Vane	Graphite	4
	91650V2000	Pins L2000			17	55820VPMNP	Internal magnet	PP/NdFeB	1
6	96610D050025V	Lock pins	PVDF	2	18	55610VPM	Rear casing	PP	1
7	902203430S	Sleeve rotor	SiC	2	19	56110VPM10C	Bracket	WCB	1
8	56610D050009V	Lock pins sleeve rotor	PVDF	2	20	55810T107210N	External magnet	A105/NdFeB	1
9	91650VPMV	Guide pins	PVDF	1	21	901508021443A	Cover reinforcing ring	AISI 316	1
10	50160VPMVF	Rotor	PVDF 10%FC	1					
11	91630N0816A2	Washer UNI6592 D.8x16	A2-70	4					

- This drawing is for reference only

EXPLODED VIEW

CODE: E 10447 Rev.:01

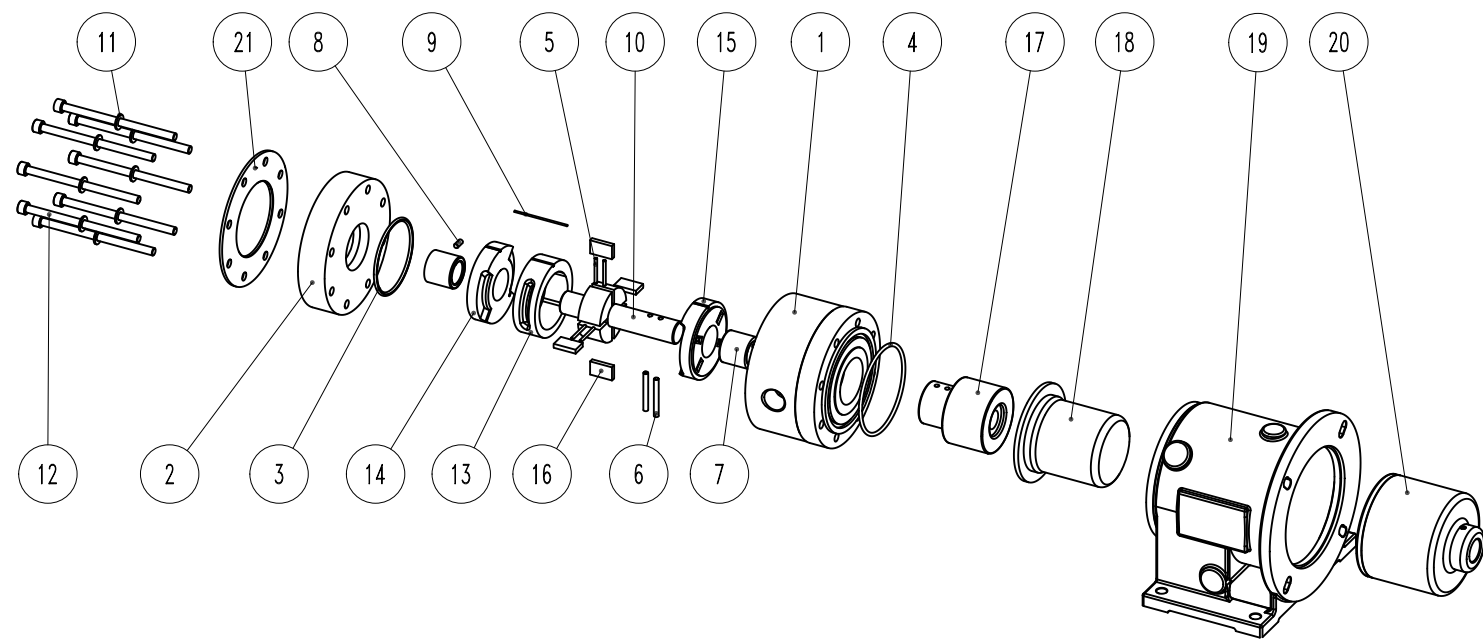

ITEM: Pump model: VPM PVDF

PART LIST

Motor: IEC 90 B3/B5
 Port connection: Threaded
 BSP-F UNI ISO 228/1 | NPT-F USAS B2-1/1968

ITEM N°	META CODE	Description	Material	Q.ty	ITEM N°	META CODE	Description	Material	Q.ty
1	56220VPMVG	Pump Casing BSP	PVDF	1	12	91610TCEI8130A2	Screw UNI5931 M8x130	A2-70	8
	56220VPMVN	Pump Casing NPT			13	92410FVB10	Stator VB 1000 L/h	Graphite	1
2	55520VPMV	Pump casing cover	PVDF	1	92410FVM15	Stator VM 1500 L/h	Graphite		
3	92910V7580	O-Ring 4300/BS234	Viton	1	92410FVM20	Stator VM 2000 L/h		Graphite	1
4	92910V9167	O-Ring 4362/BS239	Viton	1	14	91110FVPMAS	Front Disc		
5	91650V1000	Pins L1000	PVDF	4	15	91110FVPMPS	Rear Disc	Graphite	1
	91650V1500	Pins L1500			16	92010FVM	Vane	Graphite	4
	91650V2000	Pins L2000			17	55820VPMNV	Internal magnet	PVDF/NdFeB	1
6	96610D050025V	Lock pins	PVDF	2	18	55610VPMV	Rear casing	PVDF	1
7	902203430S	Sleeve rotor	SiC	2	19	56110VPM10C	Bracket	WCB	1
8	56610D050009V	Lock pins sleeve rotor	PVDF	2	20	55810T107210N	External magnet	A105/NdFeB	1
9	91650VPMV	Guide pins	PVDF	1	21	901508021443A	Cover reinforcing ring	AISI 316	1
10	50160VPMVF	Rotor	PVDF 10%FC	1					
11	91630N0816A2	Washer UNI6592 D.8x16	A2-70	4					

- This drawing is for reference only